

September 21, 2013

# ANALYTIC METHODS IN CONVEX GEOMETRY

DMITRY RYABOGIN AND ARTEM ZVAVITCH

*Dedicated to the memory of Joram Lindenstrauss, 1936-2012 and Aleksander Pelczynski 1932-2012*

## CONTENTS

|  |    |
|--|----|
| 1. The General Plan  | 2  |
| 2. Short Introduction  | 3  |
| 2.1. Main definitions and facts  | 3  |
| 2.2. Brunn-Minkowski inequality  | 5  |
| 3. Duality and Volume, the first look  | 9  |
| 3.1. $\mathbb{R}^2$ -case  | 13 |
| 3.2. Unconditional case  | 14 |
| 3.3. Local Minimum   | 17 |
| 4. Zonoids and Zonotopes   | 28 |
| 4.1. Mahler conjecture: case of zonoids.   | 30 |
| 5. Radon and Cosine Transforms   | 32 |
| 6. Local and Equatorial characterizations of Zonoids   | 37 |
| 6.1. A motivating example  | 38 |
| 6.2. Local equatorial characterization   | 40 |
| 6.3. Local characterization  | 42 |
| 7. What information can uniquely define a convex body?   | 44 |
| 7.1. Questions of Bonnensen and Klee   | 46 |
| 8. Isomorphic version of the Mahler conjecture   | 51 |
| 8.1. Introduction  | 51 |
| 9. Part I. Main Idea: the application of the Paley-Wiener Theorem  | 53 |
| 10. Part II. The adjustment of the main idea to the context of the Bergman<br>space $A^2(T_K)$   | 54 |
| 10.1. The Rothaus-Korányi-Hsin formula for the reproducing kernel in a tube<br>domain $T_K$  | 54 |
| 10.2. Estimates related to the Bergman Kernel in the tube domain   | 54 |
| 11. Part III. The auxiliary construction   | 56 |
| 11.1. The construction of the the pluri-sub-harmonic $\phi$ on the tube domain $T_K$   | 56 |
| 11.2. The construction of the Mexican-hat function $g$ supported on $K_{\mathbb{C}}$   | 57 |
| 12. Part IV. The construction of the analytic function $F$ that helps to obtain<br>the sharp lower bound on $v_{2n}(K_{\mathbb{C}})\mathcal{K}(0,0)$ | 58 |
| Appendix A. The Paley-Wiener Theorem   | 59 |
| Appendix B. The Bergman Spaces   | 61 |

---

The authors were supported in part by the Institute of Mathematics, Polish Academy of Sciences and U.S. National Science Foundation grant DMS-1101636.

|  |    |
|--|----|
| B.1. Reproducing kernel  | 61 |
| Appendix C. The Hörmander Theorem and some of its applications   | 61 |
| C.1. Convexity and Pseudo-Convexity  | 62 |
| C.2. Formulation of the Hörmander theorem  | 65 |
| C.3. From sub-harmonic to analytic. Examples in the case $n = 1$   | 66 |
| C.4. The example of a non-trivial analytic function $F = F(\phi, g)$ obtained after the application of the Hörmander Theorem in the strip $\Omega = T_K$ | 68 |
| Appendix D. Proof of Hörmander's Theorem   | 70 |
| References   | 73 |

## 1. THE GENERAL PLAN

These lecture notes are devoted to duality phenomena in Convex Geometry and different analytic methods for its study.

The notion of duality is one of the most important ones in mathematics. It plays a central role in Functional Analysis and Convex Geometry. It is hard to believe, but there are still many "classical" open problems tightly connected to this notion. Our main goal here is to discuss some of these problems.

In these lectures we will frequently use theorems, facts and general techniques from [Ba4, Ga1, Ga2, K5, KY, MS, Pi, Sc2, Web]. At first we will review some classical background and refresh some facts from Convex Geometry. In particular, we will remind the reader the F. John Theorem and the Brunn-Minkowski Inequality.

Next, we will discuss the notion of duality, the volume product and present a proof of the Santaló inequality. We continue our discussion with the Mahler conjecture, asking about the minimum of the volume product of a convex body and its polar. The conjecture is open (even in the three-dimensional case) since 1939 and has been confirmed only for some particular classes of bodies. We will present the solution in the two-dimensional case and in the case of unconditional bodies. We will also discuss some new results and show that the unit cube is a local minimizer for the volume product.

After that we will define Zonotopes and Zonoids. This class of bodies will be our main playground to test different conjectures for correctness, for example, we will verify the Mahler's conjecture for Zonoids.

Harmonic Analysis is an extremely helpful tool to understand the behavior of volume under duality: we will discuss Koldobsky's method of representing the Spherical Radon and the Cosine transforms using the language of the Fourier transform of distributions. As an application we will present results on the local characterization of Zonoids.

We will also talk about questions of the unique determination of convex bodies by the volumes of their projections and sections. In particular, we will discuss recent results related to the problems of Bonnesen and the solutions of the problems of Klee.

We will finish the lectures by presenting Nazarov's proof of the Bourgain-Milman inequality, which is an isomorphic version of the Mahler conjecture.

In many cases, writing down all details would take us away from the main point. Therefore, when the details become too tedious, we prefer to provide the reader with the

exact reference to the book or the paper, where the rigorous proof of the corresponding fact can be found.

To help the reader with the understanding of the material, we include in the text many exercises of various difficulty.

**Acknowledgment.** We would like to thank Radoslaw Adamczak, Rafal Latala, Piotr Mankiewicz, Krzysztof Oleszkiewicz, Pawel Wolff and other colleagues in Warsaw for organization of these lectures and for the wonderful time we had in Warsaw. We are very grateful to Fedor Nazarov for a number of suggestions and for letting us use his published (and unpublished!) results. We would also like to thank Jaegil Kim for helpful advice during the preparation of these lecture notes.

## 2. SHORT INTRODUCTION

**2.1. Main definitions and facts.** As usual,  $\mathbb{S}^{n-1}$  denotes the unit sphere,  $B_2^n$  the unit Euclidean ball,  $0$  is the origin, and  $|\cdot|$  the norm in Euclidean  $n$ -space  $\mathbb{R}^n$ . If  $x, y \in \mathbb{R}^n$ , then  $x \cdot y$  is the inner product of  $x$  and  $y$  and  $[x, y]$  denotes the line segment with endpoints  $x$  and  $y$ .

If  $X$  is a set,  $\dim(X)$  is its *dimension*, that is, the dimension of its affine hull, and  $\partial X$  is its *boundary*. A set is *o-symmetric* if it is centrally symmetric, with center at the origin.

If  $X$  and  $Y$  are sets in  $\mathbb{R}^n$ , then

$$X + Y = \{x + y : x \in X, y \in Y\}$$

is the *Minkowski sum* of  $X$  and  $Y$ .

A *body* is a compact set equal to the closure of its interior. A body  $K \subset \mathbb{R}^n$  is called *star-shaped* if every straight line through the origin intersects the boundary of  $K$  at exactly two points different from the origin. The Minkowski functional of  $K$  is defined as

$$\|x\|_K = \min\{a > 0 : x \in aK\},$$

which is a continuous function on  $\mathbb{R}^n$ . A radial function  $\rho_K(x) : \mathbb{R}^n \setminus \{0\} \rightarrow \mathbb{R}^+$  is defined by

$$\rho_K(x) = \max\{a > 0 : ax \in K\}.$$

Notice that  $\rho_K(x) = \|x\|_K^{-1}$ .

For a  $k$ -dimensional set  $A \subset \mathbb{R}^n$  we write  $|A|$  for the  $k$ -dimensional Lebesgue measure in  $\mathbb{R}^n$ ,  $k = 1, \dots, n$ . If  $K$  is a  $k$ -dimensional body in  $\mathbb{R}^n$ , then we refer to  $|K|$  as its *volume*.

A set  $K \subset \mathbb{R}^n$  is called *convex*, if  $[x, y] \subset K$ , for all  $x, y \in K$ . A set in  $\mathbb{R}^n$  is called a *convex body* if it is convex and compact with nonempty interior. We denote by  $\text{conv}(A)$  the closed convex hull of a set  $A \subset \mathbb{R}^n$ , and  $\text{conv}(A, B, C, \dots)$  the closed convex hull of  $A \cup B \cup C, \dots$

**Exercise 2.1.** Show that  $K$  is a convex symmetric body iff  $\|x\|_K$  is a norm on  $\mathbb{R}^n$ . Show that  $x \in K$  iff  $\|x\|_K \leq 1$ .

**Exercise 2.2.** Show that if  $K$  and  $L$  are star-shaped bodies, then  $K \subset L$  iff  $\|x\|_K \geq \|x\|_L$ , or, equivalently  $\rho_K(x) \leq \rho_L(x)$ , for every  $x \in \mathbb{S}^{n-1}$ .

We denote

$$B_\infty^n = \{x \in \mathbb{R}^n : \max_{1 \leq i \leq n} |x_i| \leq 1\} \text{ and } B_p^n = \{x \in \mathbb{R}^n : \sum_{i=1}^n |x_i|^p \leq 1\} \text{ for } 1 \leq p < \infty.$$

**Exercise 2.3.** Show that

$$|B_p^n| = \frac{\left(2\Gamma\left(1 + \frac{1}{p}\right)\right)^n}{\Gamma\left(1 + \frac{n}{p}\right)},$$

also show that  $|\mathbb{S}^{n-1}| = n|B_2^n|$ .

**Hint:** Use two ways to compute  $\int_{\mathbb{R}^n} e^{-\sum_{i=1}^n |x_i|^p} dx$ , see ([Pi], page 11).

The set of convex bodies is "pretty large". For many problems we would like to make it "smaller", so sometimes it makes sense to study the convex bodies up to linear transformations.

**Definition 2.1.** Let  $K, L \subset \mathbb{R}^n$  be convex symmetric bodies. Then the Banach-Mazur distance between these bodies is defined by

$$d_{BM}(K, L) = \min\{d > 0 : K \subset TL \subset dK; T \in GL(n)\}.$$

**Exercise 2.4.** Show that

- $d_{BM}(TK, L) = d_{BM}(K, L)$  for all  $T \in GL(n)$ .
- $d_{BM}(K, L) \leq d_{BM}(K, M)d_{BM}(M, L)$ .

We will frequently use the following theorem, which will help us to approximate a convex symmetric body by an ellipsoid. One of the consequences of this theorem is that the set of convex symmetric bodies in  $\mathbb{R}^n$  is compact with respect to the Banach-Mazur distance.

**Theorem 2.1.** (F. John) For any convex symmetric body  $K \subset \mathbb{R}^n$ , we get

$$d_{BM}(K, B_2^n) \leq \sqrt{n}.$$

*Proof.* Let  $E$  be an ellipsoid of maximal volume inscribed in  $K$ , i.e.  $E \subset K$  and

$$|E| = \max\{|D| : D \text{ is an ellipsoid and } D \subset K\}.$$

Our goal is to show that  $K \subset \sqrt{n}E$ . The Banach-Mazur distance is invariant under linear transformations, so we may assume that  $E = B_2^n$ . If  $K \not\subset \sqrt{n}B_2^n$ , then there exists  $p \in K$  so that  $|p| > \sqrt{n}$ . Applying convexity and symmetry of  $K$  we get that

$$D = \text{conv}(B_2^n, p, -p) \subset K.$$

We would like to show that  $D$  (and thus  $K$ ) contains an ellipsoid of the volume which is larger than the volume of  $B_2^n$ , this would contradict an assumption that  $B_2^n$  is the ellipsoid of the maximal volume in  $K$ . Without loss of generality we may assume that  $p = (d, 0, \dots, 0)$  and  $d > \sqrt{n}$ . Consider an ellipsoid

$$E' = \{x \in \mathbb{R}^n : \frac{x_1^2}{a^2} + \sum_{i=2}^n \frac{x_i^2}{b^2} \leq 1\}.$$

Then  $|E'| = ab^{n-1}|B_2^n|$  and if  $\frac{a^2}{d^2} + (1 - \frac{1}{d^2})b^2 \leq 1$ , then  $E' \subset D$ . Indeed,  $E'$  and  $D$  are rotation invariant around  $x_1$ , thus to check  $E' \subset D$  we need to make two dimensional calculation in  $(x_1, x_2)$ .

It is easy to check that  $a = d/\sqrt{n}$ ,  $b = \sqrt{1 - 1/n}/\sqrt{1 - 1/d^2}$  satisfy this last condition and  $ab^{n-1} > 1$ .  $\square$

**Exercise 2.5.** Prove that  $d_{BM}(B_\infty^n, B_2^n) = \sqrt{n}$ .

**Hint:** It is easy to see that  $d_{BM}(B_\infty^n, B_2^n) \leq \sqrt{n}$ . To prove the reverse inequality consider  $T \in GL(n)$  such that  $TB_2^n \subset B_\infty^n \subset dTB_2^n$ , check the conditions you will get on the diagonal elements of  $T$ , from the fact that  $e_i \notin TB_2^n$ . Also check the conditions on the elements of  $dT$ , it will help to notice that the vertices of  $B_\infty^n$  must be outside of  $TB_2^n$ , and to study them as a random vector with  $\pm 1$  coordinates.

**Definition 2.2.** The support function  $h_K : \mathbb{R}^n \rightarrow \mathbb{R}^+$  of a convex body  $K \subset \mathbb{R}^n$  is defined by

$$h_K(x) = \max_{y \in K} x \cdot y.$$

**Lemma 2.1.** If  $K$  and  $L$  are convex bodies in  $\mathbb{R}^n$  then

$$h_{K+L} = h_K + h_L.$$

**Exercise 2.6.** Prove Lemma 2.1.

**Exercise 2.7.** Show that for a convex body  $K$ ,  $x \in K$  iff for all  $y \in \mathbb{R}^n$  we have  $x \cdot y \leq h_K(y)$ . Also prove that if  $K, L$  are convex bodies then  $K \subset L$  iff  $h_K(x) \leq h_L(x)$ , for all  $x \in \mathbb{R}^n$ .

**Exercise 2.8.** Consider a convex body  $K \subset \mathbb{R}^n$ . Show that  $\nabla h_K(\xi)$  exists for almost all  $\xi \in \mathbb{S}^{n-1}$  and, moreover, if it exists, then  $\nabla h_K(\xi) \in \partial K$  and  $\xi$  is a normal vector to  $K$  at  $\nabla h_K(\xi)$ .

## 2.2. Brunn-Minkowski inequality.

**Theorem 2.2.** (Brunn-Minkowski inequality) Let,  $A, B$  be two measurable, non-empty sets in  $\mathbb{R}^n$ . Then,

$$(1) \quad |A + B|^{1/n} \geq |A|^{1/n} + |B|^{1/n}.$$

Equivalently, for all  $\lambda \in [0, 1]$

$$(2) \quad |\lambda A + (1 - \lambda)B| \geq |A|^\lambda |B|^{1-\lambda}, \text{ for all } \lambda \in [0, 1].$$

*Proof.* We will sketch the proof of (1) due to Lusternik [Lus]. We refer to [Ga2] for other proofs. We first consider the case when  $A, B$  are  $n$ -dimensional boxes. The volume is invariant under the translation, so we may assume that one of the vertices of  $A$  and  $B$  is the origin:

$$A = \prod_{i=1}^n [0, a_i] \text{ and } B = \prod_{i=1}^n [0, b_i]$$

Thus  $A + B = \prod_{i=1}^n [0, a_i + b_i]$ . But then

$$\begin{aligned} \left( \frac{|A|}{|A+B|} \right)^{\frac{1}{n}} + \left( \frac{|B|}{|A+B|} \right)^{\frac{1}{n}} &= \left( \prod_{i=1}^n \frac{a_i}{a_i + b_i} \right)^{\frac{1}{n}} + \left( \prod_{i=1}^n \frac{b_i}{a_i + b_i} \right)^{\frac{1}{n}} \\ &\leq \frac{1}{n} \left( \sum_{i=1}^n \frac{a_i}{a_i + b_i} \right) + \frac{1}{n} \left( \sum_{i=1}^n \frac{b_i}{a_i + b_i} \right) = 1. \end{aligned}$$

Now suppose that  $A$  is the union of  $m_1$  disjoint rectangular boxes and  $B$  is the union of  $m_2$  disjoint rectangular boxes. We will prove (1) by the induction on the number  $m_1 + m_2$ . The case  $m_1 + m_2 = 2$  is checked, so we may assume that  $m_1 + m_2 > 2$  and that  $A$  contains at least 2 disjoint boxes.

Again, (1) is invariant under the translation. Hence, we may assume that at least two boxes of  $A$  are separated by the coordinate plane  $x_n = 0$ . Let  $A^+ = \{x \in A : x_n \geq 0\}$  and  $A^- = \{x \in A : x_n \leq 0\}$ . By the construction, the number of boxes in each  $A^+$  and  $A^-$  is smaller than  $m_1$ .

Next, translate  $B$  so that

$$\frac{|A^+|}{|A|} = \frac{|B^+|}{|B|} \quad \text{and, thus,} \quad \frac{|A^-|}{|A|} = \frac{|B^-|}{|B|},$$

where  $B^+ = \{x \in B : x_n \geq 0\}$  and  $B^- = \{x \in B : x_n \leq 0\}$ . Notice that the sets  $A^+ + B^+$  and  $A^- + B^-$  are disjoint (up to a set of volume zero) and

$$(A^+ + B^+) \cup (A^- + B^-) \subset A + B.$$

Moreover, we can apply the induction hypothesis to  $A^+ + B^+$  and  $A^- + B^-$  to get

$$\begin{aligned} |A + B| &\geq |A^+ + B^+| + |A^- + B^-| \geq (|A^+|^{1/n} + |B^+|^{1/n})^n + (|A^-|^{1/n} + |B^-|^{1/n})^n \\ &= |A^+| \left( 1 + \frac{|B^+|^{1/n}}{|A^+|^{1/n}} \right)^n + |A^-| \left( 1 + \frac{|B^-|^{1/n}}{|A^-|^{1/n}} \right)^n \\ &= |A^+| \left( 1 + \frac{|B|^{1/n}}{|A|^{1/n}} \right)^n + |A^-| \left( 1 + \frac{|B|^{1/n}}{|A|^{1/n}} \right)^n = (|A|^{1/n} + |B|^{1/n})^n. \end{aligned}$$

□

**Exercise 2.9.** Finish the proof of the Brunn-Minkowski inequality, i.e. show that it is enough to prove (1) for  $A$  and  $B$  that are disjoint union of boxes.

**Exercise 2.10.** Note that (2) easily follows from (1). Prove that the reverse direction is, unexpectedly, also true. **Hint:** use (2) with  $A = K/|K|^{1/n}$ ,  $B = L/|L|^{1/n}$  and  $\lambda = |K|^{1/n}/(|K|^{1/n} + |L|^{1/n})$ .

Using the Brunn-Minkowski inequality one can obtain a number of properties of convex bodies. Below we consider several applications of this inequality that will be very useful for us.

For direction  $\xi \in \mathbb{S}^{n-1}$ , we denote by  $\xi^\perp$  the hyperplane perpendicular to  $\xi$ , i.e.

$$\xi^\perp = \{x \in \mathbb{R}^n : x \cdot \xi = 0\}.$$

**Definition 2.3.** Consider a body  $K \subset \mathbb{R}^n$ , and a direction  $\xi \in \mathbb{S}^{n-1}$  then we define a function  $A_{K,\xi}(t) : \mathbb{R} \rightarrow \mathbb{R}^+$  such that

$$A_{K,\xi}(t) = |K \cap \{\xi^\perp + t\xi\}|.$$

**Corollary 2.1. (Brunn's Theorem)** Consider a convex body  $K \subset \mathbb{R}^n$ , then  $A_{K,\xi}^{\frac{1}{n-1}}(t)$  is concave on its support. Moreover, if  $K$  is symmetric then  $A_{K,\xi}(0) \geq A_{K,\xi}(t)$ , for all  $t \in \mathbb{R}$ .

*Proof.* It is enough to note that from convexity of the body  $K$  we get

$$\lambda(K \cap \{\xi^\perp + t_1\xi\}) + (1 - \lambda)(K \cap \{\xi^\perp + t_2\xi\}) \subset (K \cap \{\xi^\perp + [\lambda t_1 + (1 - \lambda)t_2]\xi\}).$$

□

**Exercise 2.11.** Is it possible to guarantee the convexity of  $K$  from the concavity of  $A_{K,\xi}^{\frac{1}{n-1}}(t)$ ? More precisely:

- Show that if  $K \subset \mathbb{R}^2$  is a star shaped body and  $A_{K,\xi}(t)$  is concave on its support, then  $K$  is convex.
- Show that the above statement is not true in  $\mathbb{R}^3$ , i.e. construct an example of a non-convex star-shaped origin-symmetric body  $K \subset \mathbb{R}^3$  such that its section function  $A_{K,\xi}^{\frac{1}{2}}(t)$  is concave on its support for every fixed direction  $\xi \in \mathbb{S}^2$ . **Hint:** Use rotation invariant bodies, see more formulas in [GR].

**Definition 2.4.** Assume that  $K \subset \mathbb{R}^n$  and that the boundary  $\partial K$  of  $K$  is smooth. Then the Minkowski volume of  $\partial K$  is defined by

$$|\partial K| = \lim_{t \rightarrow 0} \frac{|K + tB_2^n| - |K|}{t},$$

provided that the limit exists.

**Exercise 2.12.** Consider a convex polytope  $P \subset \mathbb{R}^n$  with  $(n - 1)$ -dimensional faces  $\{F_i\}_{i=1}^m$ . Show that the Minkowski volume of  $\partial K$  is  $\sum |F_i|$ .

**Corollary 2.2.** Assume  $|K| = |B_2^n|$ , then  $|\partial K| \geq |\mathbb{S}^{n-1}|$ .

*Proof.* Corollary follows from the definition of  $|\partial K|$  and the Brunn-Minkowski inequality:

$$(3) \quad |\partial K| = \lim_{t \rightarrow 0} \frac{|K + tB_2^n| - |K|}{t} \geq \lim_{t \rightarrow 0} \frac{(|K|^{1/n} + |tB_2^n|^{1/n})^n - |K|}{t}$$

$$(4) \quad = n|K|^{\frac{n-1}{n}}|B_2^n|^{1/n} = |\mathbb{S}^{n-1}|.$$

Here we used that  $|\mathbb{S}^{n-1}| = n|B_2^n|$ . □

A consequence of the Minkowski theorem, (Theorem 5.1.6 in [Sc2]), tells us that if  $K, L \subset \mathbb{R}^n$  are convex bodies, then  $|K + tL|$  is a polynomial in  $t \geq 0$ , with positive coefficients:

$$|K + tL| = \sum_{k=0}^n \binom{n}{k} V_k(K, L)t^k.$$

Here  $V_i(K, L)$  is called the  $i$ -th mixed volume of  $K$  and  $L$ . We will not need the above identity in these lecture notes, but we will use analytic properties of  $V_1(K, L)$ , for which we may give an alternative definition:

**Definition 2.5.** *If  $K$  and  $L$  are convex bodies in  $\mathbb{R}^n$ , the mixed volume  $V_1(K, L)$  is equal to*

$$V_1(K, L) = \frac{1}{n} \lim_{t \rightarrow 0} \frac{|K + tL| - |K|}{t}.$$

Applying the Brunn-Minkowski inequality, as in the proof of Corollary 2.2, we get:

**Corollary 2.3.** *(First Minkowski Inequality) For any convex bodies  $K, L \subset \mathbb{R}^n$ ,*

$$V_1(K, L) \geq |K|^{\frac{n-1}{n}} |L|^{\frac{1}{n}}.$$

Consider a convex polytope  $P \subset \mathbb{R}^n$  with  $(n-1)$ -dimensional faces  $\{F_i\}_{i=1}^m$  and the corresponding normal vectors  $u_i \in \mathbb{S}^{n-1}$  to  $F_i$ . Using the formula for the volume of the pyramid and the definition of the support function  $h_P$ , we get

$$(5) \quad |P| = \frac{1}{n} \sum_{i=1}^m h_P(u_i) |F_i|.$$

Let  $K|\theta^\perp$  be the orthogonal projection of  $K$  onto hyperplane perpendicular to the unit vector  $\theta$ . It is easy to see that then  $|F_i|\theta^\perp| = |u_i \cdot \theta| |F_i|$  (indeed,  $u_i \cdot \theta$  is just a cosine of the angle between the normal vector  $u_i$  and the direction  $\theta$ ). This gives the well-known Cauchy formula:

$$(6) \quad |P|\theta^\perp| = \frac{1}{2} \sum_{i=1}^m |F_i|\theta^\perp| = \frac{1}{2} \sum_{i=1}^m |u_i \cdot \theta| |F_i|.$$

**Exercise 2.13.** *Find among  $B_\infty^n|\xi^\perp$ ,  $\xi \in \mathbb{S}^{n-1}$ , the one with maximal volume; minimal volume. Do the same for the projections of  $B_1^n$ .*

Finally, we can also create a formula for  $V_1(P, L)$ . Indeed, it is enough to understand how the volume of  $P$  is changing under the addition of  $tL$ , for very small  $t$ . Moreover, we only need to consider the rate of change of the volume of the order  $t$  (the rate  $t^2$  will be canceled after taking the limit). When we add  $tL$  to  $P$ , each face  $F_i$  moves outward by  $th_L(u_i)$  in the direction of  $u_i$ . Adding up these changes we get

$$(7) \quad V_1(P, L) = \frac{1}{n} \sum_{i=1}^m h_L(u_i) |F_i|.$$

Formulas (5), (6) and (7) are extremely useful for our lecture notes. We will also need their generalizations from polytopes to the case of general convex bodies. In the general case the formulas can be obtained by the approximation argument; but at first we need to generalize the notion of the volume measure of the face.

**Definition 2.6.** *The surface area measure  $S(K, \cdot)$  of a convex body  $K$  in  $\mathbb{R}^n$  is a finite Borel measure on  $\mathbb{S}^{n-1}$ , such that for every Borel set  $E \subset \mathbb{S}^{n-1}$ ,  $S(K, E)$  is the volume of the part of  $\partial K$  where normal vector belongs to  $E$ . If  $S(K, \cdot)$  is absolutely continuous with respect to the Lebesgue measure on  $\mathbb{S}^{n-1}$ , then the density  $f_K$  of  $S(K, \cdot)$  is called the curvature function.*

**Exercise 2.14.** Consider a polytope  $P$ , compute  $S(P, \cdot)$ .

**Exercise 2.15.** Let  $K$  be a convex body with  $C^2$ -smooth boundary. Assume also that the gaussian curvature at each point of  $\partial K$  is positive. Prove that  $S(K, \cdot)$  is absolutely continuous. **Hint:** in this case the surface area measure is the reciprocal of the Gaussian curvature, viewed as a function of the unit normal vector.

**Exercise 2.16.** Compute  $f_{B_p^n}$  for  $p \in (1, \infty)$ . **Hint:** see [KRZ].

Using the approximation argument and the above definition we get the following theorem:

**Theorem 2.3.** Consider a convex body in  $K \subset \mathbb{R}^n$ , then

- (1)  $|K| = \frac{1}{n} \int_{\mathbb{S}^{n-1}} h_K(u) dS(K, u)$ .
- (2)  $|K|\theta^\perp| = \frac{1}{2} \int_{\mathbb{S}^{n-1}} |u \cdot \theta| dS(K, u)$ .
- (3)  $V_1(K, L) = \frac{1}{n} \int_{\mathbb{S}^{n-1}} h_L(u) dS(K, u)$ .

### 3. DUALITY AND VOLUME, THE FIRST LOOK

Consider a convex symmetric body  $K \subset \mathbb{R}^n$ . We define a polar body  $K^\circ$  of  $K$  as

$$K^\circ = \{y \in \mathbb{R}^n : y \cdot x \leq 1 \text{ for all } x \in K\}.$$

Clearly  $h_K = \|x\|_{K^\circ} = \rho_{K^\circ}^{-1}(x)$ .

One can also give the definition of the duality for a non-symmetric case: *polar body*  $K^z$  of a convex body  $K$  with center of polarity  $z$  is defined by

$$K^z = \{y \in \mathbb{R}^n : (y - z) \cdot (x - z) \leq 1 \text{ for all } x \in K\}.$$

If the center of polarity is taken to be the origin, we denote by  $K^\circ$  the polar body of  $K$ , thus  $K^z = (K - z)^\circ + z$ .

A well known result of Santaló [Sa] states that in every convex body  $K$  in  $\mathbb{R}^n$ , there exists a unique point  $s(K)$ , called the *Santaló point* of  $K$ , such that

$$|K^{s(K)}| = \min_{z \in \text{int}(K)} |K^z|.$$

**Exercise 3.1.** Prove the existence and uniqueness of  $s(K)$  (**Hint:** see [Sc2], p. 419). Also prove that  $s(K) = 0$ , provided  $K$  is symmetric.

**Definition 3.1.** The volume product of  $K$  is defined by

$$\mathcal{P}(K) = \inf\{|K||K^z| : z \in \text{int}(K)\} = |K| |K^{s(K)}|,$$

thus if  $K$  is a symmetric convex body then

$$\mathcal{P}(K) = |K| |K^\circ|.$$

**Lemma 3.1.** Here we list the main properties of duality and volume product for convex bodies containing the origin in their interior.

- (1) We have  $(K^\circ)^\circ = K$ .
- (2) If  $K \subset L$ , then  $L^\circ \subset K^\circ$ .

- (3) The volume product is invariant under the non-degenerate linear transformations, that is,  $(TK)^\circ = (T^*)^{-1}K^\circ$  and thus  $\mathcal{P}(T(K)) = \mathcal{P}(K)$ , for all  $T \in GL(n)$ .
- (4) We have  $(K \cap \xi^\perp)^\circ = K^\circ|_{\xi^\perp}$ .

**Remark 3.1.** We note that the property  $(K \cap \xi^\perp)^\circ = K^\circ|_{\xi^\perp}$  shows that the operation of duality transforms **sections** of the given body into **projections** of the dual one. It is the origin for understanding of statements of duality between subspaces and quotient spaces in Functional Analysis.

**Exercise 3.2.** Let  $K = [-5, -4]$ , find  $(K^\circ)^\circ$ .

**Exercise 3.3.** Prove Lemma 3.1. Note that (3) follows from the fact that  $Tx \cdot (T^*)^{-1}y = x \cdot y$ , for  $T \in GL(n)$ .

**Exercise 3.4.** Show that for convex, symmetric bodies  $K, L \subset \mathbb{R}^n$

$$(K \cap L)^\circ = \text{conv}(K^\circ, L^\circ).$$

**Exercise 3.5.** Let  $K, L \subset \mathbb{R}^n$  be a convex symmetric bodies. Show that

$$d_{BM}(K, L) = d_{BM}(K^\circ, L^\circ).$$

**Exercise 3.6.** Show that the map  $K \mapsto \mathcal{P}(K)$  is a continuous on the set of convex symmetric bodies equipped with the Banach-Mazur distance (**Hint:** see [FMZ]).

Since the set of all convex bodies in  $\mathbb{R}^n$  is compact with the respect to the Banach-Mazur distance and the map  $K \mapsto \mathcal{P}(K)$  is continuous (this follows from the F. John theorem and the above exercise), it is very natural to ask for a maximal and minimal values of  $\mathcal{P}(K)$ . We start with the maximum, which is given by the following Blaschke-Santaló inequality

**Theorem 3.1.** For any convex symmetric body  $K \subset \mathbb{R}^n$ ,

$$\mathcal{P}(K) \leq \mathcal{P}(B_2^n).$$

*Proof.* We will present the proof from [MePa] and [Ba]. The main tool is the Stienen Symmetrization which (in the one co-dimensional case) can be described as follows. Consider a convex body  $K \subset \mathbb{R}^n$  and a hyperplane  $u^\perp$ , where  $u \in \mathbb{S}^{n-1}$ . To get  $S_{u^\perp}(K)$  perform the following algorithm: for each point  $p \in u^\perp$  let  $l_p$  be a line through  $p$  perpendicular to  $u^\perp$  (i.e.  $l_p = p + tu$ ,  $t \in \mathbb{R}$ ). If  $K \cap l_p = \emptyset$  - do nothing, otherwise translate the segment  $K \cap l_p$  along  $l_p$  until its midpoint belongs to  $u^\perp$  (see the Figure 1).

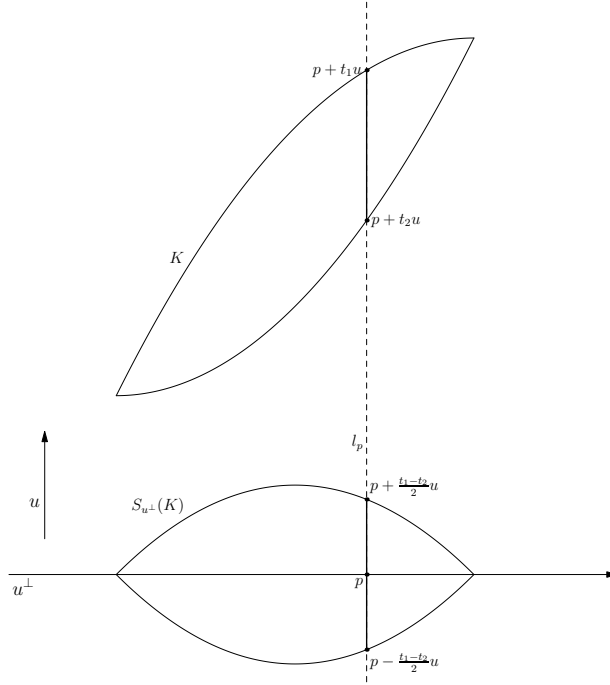

FIGURE 1. Steiner Symmetrization in  $\mathbb{R}^2$ .

More precisely, let  $K \subset \mathbb{R}^n$  be a convex body,  $U$  be a subspace of  $\mathbb{R}^n$  and  $U^\perp$  its orthogonal complement. We define the Steiner symmetrization  $S_{U^\perp}(K)$  of  $K$  with respect to  $U^\perp$  to be the set of points  $x \in \mathbb{R}^n$  for which there are  $p \in U^\perp$  and  $v, w \in U$  such that

- $x = p + \frac{v-w}{2}$
- $p + v, p + w \in K$ .

We will need the following useful facts: Assume that  $K, L$  are convex symmetric bodies in  $\mathbb{R}^n$ , then

- (a)  $S_{U^\perp}(K)$  is also a symmetric, convex body.
- (b)  $S_{U^\perp}(\cdot)$  is a monotone operation, i.e.  $S_{U^\perp}(L) \subset S_{U^\perp}(K)$ , for all  $L \subset K$ .
- (c)  $S_{U^\perp}(\lambda K) = \lambda S_{U^\perp}(K)$ , for all  $\lambda > 0$ .
- (d)  $S_{U^\perp}(B_2^n) = B_2^n$ .
- (e)  $|S_{U^\perp}(K)| \geq |K|$ .
- (f)  $S_U(K^\circ) \subset (S_{U^\perp}(K))^\circ$ .
- (g)  $\mathcal{P}(K) \leq \mathcal{P}(S_{U^\perp}(K))$ .

It is easy to check that  $S_{U^\perp}(K)$  is convex and moreover

$$(8) \quad [S_{U^\perp}(K) - p] \cap U = \frac{1}{2} [(K - p) \cap U - (K - p) \cap U].$$

We see that (e) follows from Fubini Theorem, equation (8) and the Brunn-Minkowski inequality (Theorem 2.2). Now consider  $x \in S_{U^\perp}(K)$  and  $y \in S_U(K^\circ)$ . Then

$$x = p + \frac{1}{2}(v - w), y = z + \frac{1}{2}(s - t),$$

where  $p, s, t \in U^\perp$ ;  $z, v, w \in U$ ;  $p + v, p + w \in K$  and  $z + s, z + t \in K^\circ$ . Moreover,  $p \cdot z = 0$ ,  $(v - w) \cdot (s - t) = 0$  and

$$x \cdot y = \frac{1}{2}p \cdot (s - t) + \frac{1}{2}(v - w) \cdot z = \frac{1}{2}(p + v) \cdot (z + s) - \frac{1}{2}(p + w) \cdot (z + t).$$

This gives  $|x \cdot y| \leq 1$ , which implies (f). To prove (g) we apply (e) and consider Steiner symmetrization of  $K$  and  $K^\circ$  with respect to  $U^\perp$  and  $U$ . We also use (f):

$$\mathcal{P}(K) = |K||K^\circ| \leq |S_{U^\perp}(K)||S_U(K^\circ)| \leq |S_{U^\perp}(K)|(S_{U^\perp}(K))^\circ| = \mathcal{P}(S_{U^\perp}(K)).$$

Another well known fact (see Theorem 6.6.6 [Web]) is that for any convex body  $K \subset \mathbb{R}^n$  there is a sequence of unit vectors  $\xi_1, \xi_2, \dots$  such that  $S_{\xi_i^\perp} \cdots S_{\xi_1^\perp}(K)$  converges to the Euclidian ball of volume  $|K|$  as  $i \rightarrow \infty$ .

Thus, Theorem 3.1 follows immediately from (f). □

**Exercise 3.7.** Show that for two convex bodies  $K, L \subset \mathbb{R}^n$  we have

$$S_{U^\perp}(K) + S_{U^\perp}(L) \subset S_{U^\perp}(K + L).$$

Use the above inclusion to prove Brunn-Minkowski inequality for convex bodies.

The minimality of  $\mathcal{P}(K)$  turns out to be the much harder question which is still open! It is often called the Mahler's conjecture [Ma1, Ma2], and it states that for every convex body  $K$  in  $\mathbb{R}^n$ ,

$$(9) \quad \mathcal{P}(K) \geq \mathcal{P}(\Delta^n) = \frac{(n+1)^{n+1}}{(n!)^2},$$

where  $\Delta^n$  is an  $n$ -dimensional simplex. It is also conjectured that equality in (9) is attained only if  $K$  is a simplex.

**Exercise 3.8.** Show that

$$\mathcal{P}(\Delta^n) = \frac{(n+1)^{n+1}}{(n!)^2}.$$

In our lectures we will concentrate on the symmetric case of the Mahler conjecture, which states that for every convex *symmetric* body  $K \subset \mathbb{R}^n$ :

$$(10) \quad \mathcal{P}(K) \geq \mathcal{P}(B_\infty^n) = \mathcal{P}(B_1^n) = \frac{4^n}{n!}.$$

**Exercise 3.9.** Try to prove directly, using Exercise 2.3, that

$$\mathcal{P}(B_p^n) \geq \mathcal{P}(B_\infty^n), \text{ for } p \geq 1.$$

Note, that this fact follows immediately from Theorem 3.3 (see below).

The conjecture is confirmed in  $\mathbb{R}^2$ . We will sketch this fact in the next section as well as give a complete proof as a part of the "local" minima result (see Theorem 3.4 below).

3.1.  $\mathbb{R}^2$  -case. We would like to show that

**Theorem 3.2.** (Mahler)  $\mathcal{P}(P) \geq \mathcal{P}(B_\infty^2)$  for all symmetric convex polygons  $P \subset \mathbb{R}^2$ .

*Proof.* (Sketch) The main idea is to "remove/glue" vertices. Let  $P_k$  be any given symmetric polygon with  $k$  vertices. Following Mahler, we will construct a sequence of transformations of symmetric polygon  $P_k$ :  $P_k \rightarrow P_{k-2} \rightarrow P_{k-4} \rightarrow \dots \rightarrow P_4$ , such that

$$\mathcal{P}(P_k) \geq \mathcal{P}(P_{k-2}) \geq \mathcal{P}(P_{k-4}) \geq \dots \geq \mathcal{P}(P_4) = \mathcal{P}(B_\infty^2).$$

Here the last equality follows from invariance of  $\mathcal{P}$  under linear transformations (Lemma 3.1). On each step of the construction, we will have  $|P_k| = |P_{k-2}|$  and  $|P_k^\circ| \geq |P_{k-2}^\circ|$ . In fact, the procedure is just to reduce the question to a comparison of the area of a triangle and the "dual" triangle.

The duality operation  $K \rightarrow K^\circ$  does not work "well" on polygons (bodies) that do not contain the origin (see Exercise 3.2). To overcome this difficulty, Mahler introduced another "duality like" operation:

**Definition 3.2.** Let  $K$  be a convex polytope with faces  $f_1, \dots, f_m$ . Then  $\tilde{K}$  is a polytope that has vertices  $\tilde{v}_1, \dots, \tilde{v}_m$  such that  $\tilde{v}_m \perp f_m$  and  $\text{dist}(\tilde{v}_m, 0) \cdot \text{dist}(\text{aff}(f_m), 0) = 1$ , where  $\text{aff}(f_m)$  denotes the minimal affine subspace (line in this case) containing  $f_m$ .

**Exercise 3.10.** Show that if a polytope  $K$  contains the origin, then  $\tilde{K} = K^\circ$ .

**Exercise 3.11.** Let  $v_1, v_2, v_3$  be the vertices of a triangle  $\text{conv}(v_1, v_2, v_3)$  such that  $0 \notin \text{conv}(v_1, v_2, v_3)$ . Find  $\tilde{v}_1, \tilde{v}_2$  and  $\tilde{v}_3$ , the vertices of triangle  $\text{conv}(\tilde{v}_1, \tilde{v}_2, \tilde{v}_3)$ .

Consider a polygon  $P_k$  with vertices  $v_1, v_2, v_3, \dots, v_k$ , written in the clockwise order. Let  $l$  be a line passing through  $v_2$  parallel to the segment  $v_1, v_3$ , and let  $v$  be any point on  $l$ . Then

**Exercise 3.12.** As long as  $v$  stays on  $l$  between lines  $l_{v_3, v_4}, l_{v_k, v_1}$  (passing through  $v_3, v_4$  and  $v_k, v_1$  respectively), we have  $|P_k| = |P_k(v)|$ , where  $P_k(v) := \text{conv}\{v_1, v, v_3, \dots, v_k\}$ . See Figure 2.

The main observation in this construction is

**Exercise 3.13.** Prove that

$$(11) \quad P_k(v) = P_{k-1} \cup \Delta(v), \quad \widetilde{P_k(v)} = \widetilde{P_{k-1}} \setminus \widetilde{\Delta(v)},$$

where

$$(12) \quad \Delta(v) = \text{conv}\{v_1, v, v_3\}, \quad \text{and } P_{k-1} = \text{conv}\{v_1, v_3, \dots, v_k\}.$$

Also prove that (11), (12) imply

$$(13) \quad |P_k(v)| = |P_{k-1}| + |\Delta(v)|,$$

$$(14) \quad |\widetilde{P_k(v)}| = |\widetilde{P_{k-1}}| - |\widetilde{\Delta(v)}|.$$

and thus  $|\widetilde{\Delta(v)}| \geq |\widetilde{\Delta(v_2)}|$  gives  $|\widetilde{P_k(v)}| \leq |\widetilde{P_k(v_2)}| = |\widetilde{P_k}|$ .

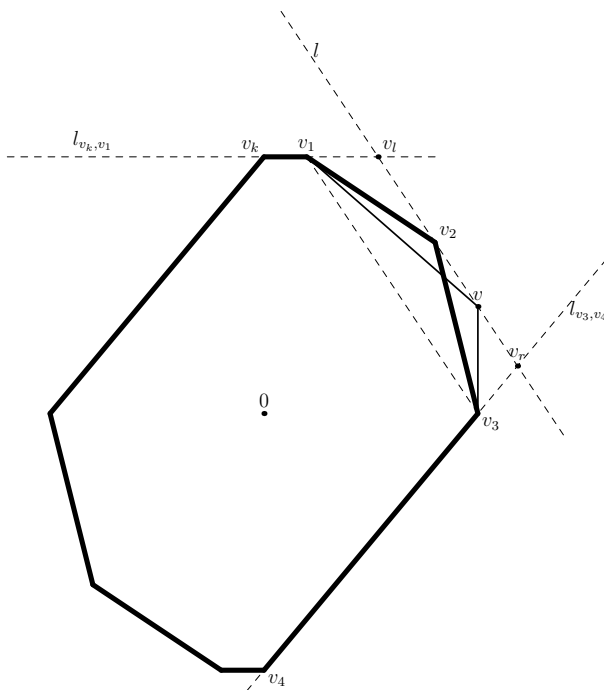

FIGURE 2. Moving vertex  $v_2$  to vertex  $v$  along the line  $l$ , keeping  $|P_k(v)|$  constant.

Let  $v_l = l \cap l_{v_k, v_1}$  and  $v_r = l \cap l_{v_3, v_4}$  (See Figure 2). To finish the proof it is enough to show that

$$(15) \quad \max\{|\widetilde{\Delta}(v_l)|, |\widetilde{\Delta}(v_r)|\} \geq |\widetilde{\Delta}(v_2)|$$

Indeed  $P_k(v_l)$  and  $P_k(v_r)$  have  $k - 1$  vertices, and it follows from Exercise 3.13 and (15) that  $\mathcal{P}(P_k) \geq \min\{\mathcal{P}(P_k(v_l)), \mathcal{P}(P_k(v_r))\}$ .

To prove (15) we need to show that the function  $f(v) = |\widetilde{\Delta}(v)|$  attains its maximum at the end points of the interval  $[v_l, v_r]$ . This can be done by using Exercise 3.11 and computing the exact formula for  $f(v)$ . □

**3.2. Unconditional case.** Let us also note that if the conjecture is true in the symmetric case, then for  $n \geq 4$ ,  $B_\infty^n$  and  $B_1^n$  is not the only minimal pair. For sets  $K \subset \mathbb{R}^{n_1}$  and  $L \subset \mathbb{R}^{n_2}$  we denote by  $K \oplus L$  their direct sum, i.e.

$$K \oplus L = \{(x, y) \in \mathbb{R}^{n_1+n_2} : x \in K, y \in L\}.$$

**Lemma 3.2.** *Consider two convex symmetric bodies  $K \subset \mathbb{R}^{n_1}$  and  $L \subset \mathbb{R}^{n_2}$ . Then*

$$\mathcal{P}(K \oplus L) = \frac{n_1!n_2!}{(n_1 + n_2)!} \mathcal{P}(K)\mathcal{P}(L).$$

*In particular,*

$$\mathcal{P}(B_1^{n_1} \oplus B_1^{n_2}) = \mathcal{P}(B_1^{n_1+n_2}).$$

*Proof.* We first notice that  $|K \oplus L| = |K||L|$ . For convex bodies  $K \subset \mathbb{R}^{n_1}$  and  $L \subset \mathbb{R}^{n_2}$  define a new convex body  $K \oplus_1 L \subset \mathbb{R}^{n_1+n_2}$  using its Minkowsky functional:

$$\|(x_1, x_2)\|_{K \oplus_1 L} = \|x_1\|_K + \|x_2\|_L, \text{ for } x_1 \in \mathbb{R}^{n_1}, x_2 \in \mathbb{R}^{n_2}.$$

**Exercise 3.14.** *Prove that:*

- $K \oplus_1 L = \text{conv}(K, L)$ .
- $(K \oplus L)^\circ = K^\circ \oplus_1 L^\circ$ .

Finally, Lemma 3.2 follows from

$$(16) \quad |K| = \frac{1}{n!} \int_{\mathbb{R}^n} e^{-\|x\|_K} dx, \text{ for } K \subset \mathbb{R}^n, K \text{ is convex, symmetric body.}$$

Indeed,

$$\int_{\mathbb{R}^n} e^{-\|x\|_K} dx = \int_{\mathbb{R}^n} \int_{\|x\|_K}^{\infty} e^{-t} dt dx = \int_0^{\infty} \int_{\|x\|_K \leq t} e^{-t} dx dt = \int_0^{\infty} |tK| e^{-t} dt = n!|K|.$$

□

**Definition 3.3.** *A symmetric convex body is called a **Hanner polytope** if it is one-dimensional, or if it is the  $\oplus$  or the  $\oplus_1$  sum of two (lower dimensional) Hanner polytopes.*

If we apply Lemma 3.2 to Hanner polytopes we immediately get that  $\mathcal{P}(H) = \mathcal{P}(B_\infty^n)$  for every Hanner polytope  $H$  in  $\mathbb{R}^n$ . Thus, starting from dimension 4 there are a lot of possible minimizers of the volume product.

**Exercise 3.15.** *Please, check the above statement, more precisely:*

- *Prove that  $\mathcal{P}(H) = \mathcal{P}(B_\infty^n)$  for every Hanner polytope  $H \subset \mathbb{R}^n$ .*
- *Show that every Hanner polytope  $H \subset \mathbb{R}^3$  is, up to a linear transformation, is  $B_\infty^3$  or  $B_1^3$ .*
- *Show that there exists a Hanner polytope  $H \subset \mathbb{R}^4$  such that it is not a linear transformation of  $B_\infty^4$  or  $B_1^4$ . **Hint:** you may use  $(I \oplus_1 I \oplus_1 I) \oplus I$ , where  $I = [-1, 1]$ .*

**Open Problem 3.1.** *Does there exist a convex symmetric body  $K \subset \mathbb{R}^3$ , such that*

$$\mathcal{P}(K) = \mathcal{P}(B_\infty^3),$$

*but  $K$  is not a linear image of  $B_1^3$  or  $B_\infty^3$ ?*

**Open Problem 3.2.** *Does there exist a convex body  $K \subset \mathbb{R}^n$ ,  $n \geq 3$  such that*

$$\mathcal{P}(K) = \mathcal{P}(\Delta_n),$$

*but  $K$  is not an affine image of  $\Delta_n$ ?*

**Open Problem 3.3.** *Assume that convex symmetric body  $K$  is a minimizer for a volume product over the set of convex symmetric bodies in  $\mathbb{R}^n$ . Is it true that  $K$  is necessary a polytope? (see [St], [RSW] and [GM] for a related discussion)*

**Definition 3.4.**  $K \subset \mathbb{R}^n$  is called unconditional if for any  $x = (x_1, x_2, \dots, x_n) \in K$  we have  $(\pm x_1, \pm x_2, \dots, \pm x_n) \in K$ .

**Exercise 3.16.** Show that there is a convex symmetric body  $K \subset \mathbb{R}^2$  (and thus in  $\mathbb{R}^n$ ) such that  $TK$  is not unconditional for all  $T \in GL(n)$ .

The following theorem is due to Saint-Raymond [SR]. We present here a proof due to Meyer [Me]:

**Theorem 3.3.** Let  $K$  be an unconditional convex body in  $\mathbb{R}^n$ , then

$$\mathcal{P}(K) \geq \mathcal{P}(B_\infty^n).$$

*Proof.* It is clear that the theorem (as well as the Mahler conjecture) is true in  $\mathbb{R}$ . Indeed, then  $K = [-a, a]$  and  $K^\circ = [-1/a, 1/a]$  for  $a > 0$ , from this we get  $\mathcal{P}(K) = 4$  for all origin-symmetric  $K \subset \mathbb{R}$ .

We will prove the theorem by induction. Define

$$K^+ = K \cap \mathbb{R}_+^n = \{x \in K : x_i \geq 0, \text{ for } i = 1, \dots, n\}.$$

Consider  $x \in K^+$  and consider  $n$  pyramids created as the convex hull of  $x$  and intersection of  $K^+$  with coordinate planes. More precisely, let

$$K_i^+ = \text{conv}\{x, K^+ \cap e_i^\perp\},$$

where  $e_1, \dots, e_n$  is the standard basis of  $\mathbb{R}^n$ . Note that the intersection of  $K_i^+$  and  $K_j^+$  has a zero volume for  $i \neq j$  (see Figure 3).

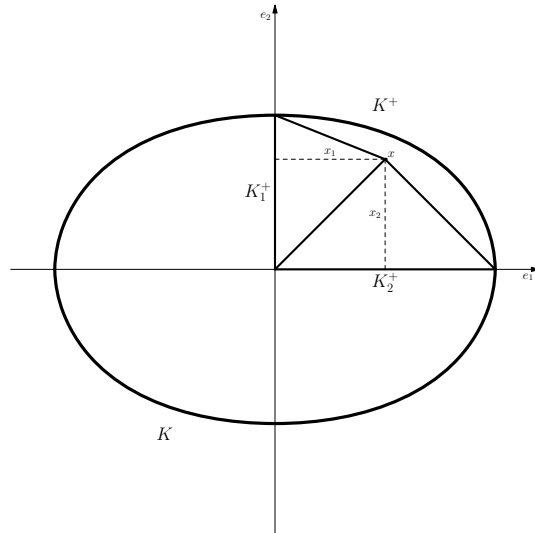

FIGURE 3. Construction of  $K_i^+$ .

Then, using the unconditionality and convexity of  $K$ :

$$|K| = 2^n |K^+| \geq 2^n \left| \bigcup_{i=1}^n K_i^+ \right| = 2^n \sum_{i=1}^n \frac{1}{n} x_i \frac{|K \cap e_i^\perp|}{2^{n-1}} = \sum_{i=1}^n x_i \left( \frac{2}{n} |K \cap e_i^\perp| \right).$$

The above inequality can be rewritten as

$$(17) \quad \sum_{i=1}^n x_i \left( \frac{2|K \cap e_i^\perp|}{n|K|} \right) \leq 1, \text{ for all } x \in K^+, \text{ and thus for all } x \in K.$$

Now (17) immediately yields the fact that the vector

$$(18) \quad \left\{ \frac{2|K \cap e_i^\perp|}{n|K|} \right\}_{i=1}^n \in K^\circ.$$

Applying the same argument to  $K^\circ$  we get

$$(19) \quad \left\{ \frac{2|K^\circ \cap e_i^\perp|}{n|K^\circ|} \right\}_{i=1}^n \in K.$$

From the definition of polarity, we know, that  $x \cdot y \leq 1$ , for all  $x \in K$  and  $y \in K^\circ$ , thus from (18) and (19) we get:

$$(20) \quad \sum_{i=1}^n \frac{2|K \cap e_i^\perp|}{n|K|} \cdot \frac{2|K^\circ \cap e_i^\perp|}{n|K^\circ|} \leq 1.$$

Next, we notice that property (4) of Lemma 3.1 gives

$$(21) \quad K^\circ \cap e_i^\perp = (K|e_i^\perp)^\circ = (K \cap e_i^\perp)^\circ,$$

where the second equality follows from the fact that  $K$  is unconditional. Finally, we use (20), (21) and the inductive hypothesis to obtain

$$|K||K^\circ| \geq \frac{4}{n^2} \sum_{i=1}^n |K \cap e_i^\perp| \cdot |(K \cap e_i^\perp)^\circ| \geq \frac{4}{n^2} n \frac{4^{n-1}}{(n-1)!} = \frac{4^n}{n!}.$$

□

**3.3. Local Minimum.** In his blog on the Mahler conjecture T. Tao [T] asked whether the cube  $B_\infty^n$  is a local minimizer. More precisely, is it possible to select  $\delta > 0$  such that if

$$U_\delta(B_\infty^n) := \{K \text{ convex, symmetric body} : d_{BM}(B_\infty^n, K) \leq 1 + \delta\},$$

then the Mahler conjecture is true for all  $K \in U_\delta(B_\infty^n)$ . The following theorem from [NPRZ] answers his question:

**Theorem 3.4.** *Let  $K \subset \mathbb{R}^n$  be an origin-symmetric convex body. Then*

$$\mathcal{P}(K) \geq \mathcal{P}(B_\infty^n),$$

*provided that  $d_{BM}(K, B_\infty^n) \leq 1 + \delta$ , and  $\delta = \delta(n) > 0$  is small enough. Moreover, the equality holds only if  $d_{BM}(K, B_\infty^n) = 1$ , i.e., if  $K$  is a parallelepiped.*

The proof of the above theorem is quite involved. We will split it into several lemmata.

The first difficulty in proving local minimality of the unit cube is that there are plenty of small (linear) perturbations with the same volume product, namely all close parallelepipeds. We will overcome this difficulty by choosing a ‘‘canonical representative’’ in each class of affinely equivalent convex bodies. More precisely, we consider only the bodies  $K$  for which the unit cube is a parallelepiped of the least volume containing  $K$ .

In addition to taking care of all close parallelepipeds, it allows us to fix  $2n$  points on the boundary of  $K$  and  $K^\circ$  (the centers of the  $(n-1)$ -dimensional faces of  $B_\infty^n$ ).

**Lemma 3.3.** *Let  $P$  be a parallelepiped of minimal volume containing a convex origin-symmetric body  $K$ . Let  $T : \mathbb{R}^n \rightarrow \mathbb{R}^n$  be a linear transformation such that  $P = TB_\infty^n$ . Then  $T^{-1}K \subset B_\infty^n$  and  $\pm e_j \in \partial T^{-1}K$ ,  $j = 1, \dots, n$ .*

*Proof.* Note that  $B_\infty^n$  is a parallelepiped of minimal volume containing  $T^{-1}K$ . Assume that  $e_j \notin T^{-1}K$ . Then it is quite easy to see that we can construct a parallelepiped of smaller volume than  $B_\infty^n$ , still containing  $T^{-1}K$ . For this, just "rotate" and "push" towards the origin a facet of  $B_\infty^n$ , containing  $e_j$ . More precisely, if  $e_j \notin T^{-1}K$  then there exists an affine hyperplane  $H \ni e_j$  such that  $H \cap T^{-1}K = \emptyset$ . Note that the volume of the parallelepiped bounded by  $H, -H$ , and the affine hyperplanes  $\{x : x \cdot e_i = \pm 1\}$ ,  $i \neq j$ , equals  $|B_\infty^n|$ , and that this parallelepiped still contains  $K$ . But then we can shift  $H$  and  $-H$  towards  $K$  a little bit and get a new parallelepiped of smaller volume containing  $K$ .  $\square$

**Exercise 3.17.** *Let  $S$  be a simplex of minimal volume containing convex (not necessarily symmetric) body  $K$ . Show that all the centroids of facets of  $S$  belong to  $K$  (see [Kl] for a solution).*

From the statement of the theorem we see that we need to use the parallelepiped closest to  $K$  in Banach-Mazur distance, which is not necessarily a parallelepiped of minimal volume. Lemma 3.5 below solves this problem. But first we will prove a technical lemma, which is quite useful for our computations:

**Lemma 3.4.** *Let  $\Pi \subset \mathbb{R}^n$  be a star-shaped (with respect to the origin) polytope such that every  $(n-1)$ -dimensional face  $F$  of  $\Pi$  has area at least  $A$  and satisfies  $\text{dist}(\text{aff}(F), 0) \geq r$ , where  $\text{aff}(F)$  denotes the minimal affine subspace containing  $F$ . Let  $x \notin (1 + \mu)\Pi$  for some  $\mu > 0$ . Then*

$$|\text{conv}(\Pi, x)| \geq |\Pi| + \frac{\mu r A}{n}.$$

*Proof.* Let  $y = \partial \Pi \cap [0, x]$ . Let  $F$  be a face of  $\Pi$  containing  $y$ . Then  $\text{conv}(\Pi, x) \setminus \Pi$  contains the pyramid with base  $F$  and apex  $x$ . The assumptions of the lemma imply that the height of this pyramid is at least  $\mu \text{dist}(\text{aff}(F), 0) \geq \mu r$ , so its volume is at least  $\frac{\mu r A}{n}$ .  $\square$

Now we will show that if  $K$  is sufficiently close to  $B_\infty^n$ , then  $K$  is also close to any parallelepiped of minimal volume containing  $K$ .

**Lemma 3.5.** *Let  $K$  be a convex body satisfying*

$$(22) \quad (1 - \delta)B_\infty^n \subset K \subset B_\infty^n.$$

*Then there exist a constant  $C$  and a linear operator  $T$  such that*

$$(1 - C\delta)B_\infty^n \subset T^{-1}K \subset B_\infty^n,$$

*and  $\pm e_i \in T^{-1}K$ .*

*Proof.* Let as before  $P = TB_\infty^n$  be a parallelepiped of minimal volume containing  $K$ . Then  $K \subset P$  and our goal is to show that there is  $C > 0$  such that  $(1 - C\delta)P \subset K$ . Applying (22) we see that it is enough to show that  $(1 - C\delta)P \subset (1 - \delta)B_\infty^n$  or that there is a small  $\kappa_0$  such that  $P \subset (1 + \kappa_0)(1 - \delta)B_\infty^n$ .

Note that  $|P| \leq 2^n$  (indeed,  $K \subset B_\infty^n$ , so, by minimality,  $|P| \leq |B_\infty^n|$ ). On the other hand, if there exists a  $\kappa > 0$  such that  $x \in P \setminus (1 + \kappa)(1 - \delta)B_\infty^n$ , then, by Lemma 3.4, with  $\Pi = (1 - \delta)B_\infty^n$ ,  $r = 1 - \delta$ ,  $A = |(1 - \delta)B_\infty^{n-1}|$  and  $\mu = \kappa$ ,

$$|P| \geq |(1 - \delta)B_\infty^n| + \frac{\kappa(1 - \delta)}{n} |(1 - \delta)B_\infty^{n-1}| = 2^n(1 - \delta)^n + \kappa \frac{2^{n-1}}{n} (1 - \delta)^n.$$

The right hand side is greater than  $2^n$  if  $\kappa > \kappa_0 = 2n((1 - \delta)^{-n} - 1)$ . Thus,  $P \subset (1 + \kappa_0)(1 - \delta)B_\infty^n$ , and thereby  $(1 - \kappa_0)P \subset (1 - \delta)B_\infty^n \subset K$ . It remains to note that  $\kappa_0 \leq 4n^2\delta$  for sufficiently small  $\delta > 0$ .  $\square$

Thus, replacing  $K$  by its suitable linear image we may assume everywhere below that  $K \subset B_\infty^n$ ,  $\pm e_j \in \partial K$ ,  $j = 1, \dots, n$ . Let  $\delta > 0$  be the minimal number such that  $(1 - \delta)B_\infty^n \subset K$ .

**Exercise 3.18.** *Study the geometric and combinatorial properties of a polytope and its polar:*

- Let  $F_i$  be a face of  $B_\infty^n$ ,  $\dim(F_i) = i$ ,  $i = 0, \dots, n - 1$ . Show that there is a face  $F_i^*$  of  $B_1^n$  such that  $x \cdot y = 1$  for all  $x \in F_i$ ,  $y \in F_i^*$  and  $\dim(F_i^*) = n - 1 - i$ .
- Generalize this statement to the case of general convex polytopes  $P$  and  $P^\circ$  in  $\mathbb{R}^n$ , such that  $0$  is interior point of  $P$ . More precisely show that if  $F_i$  is  $i$ -dimensional face of  $P$ , then

$$F_i^* = \{y \in P^\circ : x \cdot y = 1, \text{ for all } x \in F_i\}$$

is  $n - 1 - i$  dimensional face of  $P^\circ$ . Moreover, the mapping  $\Psi(F_i) = F_i^*$  is one-to-one mapping between faces of  $P$  and  $P^\circ$  and  $\Psi(\Psi(F_i)) = F_i$  (see Chapter 3.4 in [Gru]).

The next construction and the lemma will give the first idea of how we will approximate  $K$  and  $K^\circ$  by polytopes. Consider flag  $\mathcal{F} = \{F_0, F_1, \dots, F_{n-1}\}$  such that  $F_0 \subset F_1 \subset \dots \subset F_{n-1}$  are faces of  $B_\infty^n$ ,  $\dim F_i = i$ , i.e.  $F_0$  is a vertex (0-dimensional face) and  $F_{n-1}$  is a facet ( $n - 1$ -dimensional face). We will denote by  $c(F_i)$  a center of face  $F_i$  and by  $c^*(F_i)$  a center of the dual face to  $F_i$ .

**Exercise 3.19.** *Show that  $c^*(F_i) = (n - \dim F_i)^{-1}c(F_i)$ .*

For each  $i \in 0, \dots, n - 1$ , fix two vectors  $y_i, y_i^*$  having the same direction as  $c(F_i)$  such that  $y_i \cdot y_i^* = 1$  (i.e.  $y_i = \alpha_i c(F_i)$  and  $y_i^* = \alpha_i^* c^*(F_i)$ , where  $\alpha_i, \alpha_i^* > 0$  and  $\alpha_i \alpha_i^* = 1$ ) and consider two simplexes:

$$S_y(\mathcal{F}) = \text{conv}\{0, y_0, \dots, y_{n-1}\} \text{ and } S_{y^*}(\mathcal{F}) = \text{conv}\{0, y_0^*, \dots, y_{n-1}^*\}.$$

Now consider

$$Q = \bigcup_{\mathcal{F}} S_y(\mathcal{F}) \text{ and } Q' = \bigcup_{\mathcal{F}} S_{y^*}(\mathcal{F}),$$

where the union is taken over all  $2^n n!$  flags of  $B_\infty^n$ .

**Lemma 3.6.**

$$|Q||Q'| \geq \mathcal{P}(B_\infty^n).$$

*Proof.* We first notice that  $|S_y(\mathcal{F})||S_{y^*}(\mathcal{F})| = 1/(n!)^3$ . Indeed, consider a simplex  $\Delta = \text{conv}\{0, c(F_0), \dots, c(F_{n-1})\}$ , then  $|\Delta| = 1/n!$ . To get the volume of  $S_y(\mathcal{F})$  or  $S_{y^*}(\mathcal{F})$  we apply to  $\Delta$  a linear transformation (see the definition of those simplexes).

We finish the proof of the lemma applying:

$$\sum_{i=1}^l d_i \sum_{i=1}^l d_i^{-1} \geq l^2, \text{ for any } d_1, \dots, d_l > 0.$$

Indeed, then

$$\begin{aligned} |Q||Q'| &= \left( \sum_{\mathcal{F}} |S_y(\mathcal{F})| \right) \left( \sum_{\mathcal{F}} |S_{y^*}(\mathcal{F})| \right) = \frac{1}{(n!)^3} \left( \sum_{\mathcal{F}} |S_y(\mathcal{F})| \right) \left( \sum_{\mathcal{F}} |S_y(\mathcal{F})|^{-1} \right) \\ &\geq \frac{(2^n n!)^2}{(n!)^3} = \mathcal{P}(B_\infty^n). \end{aligned}$$

□

We are ready to start the construction of polytopes approximating  $K$  and  $K^\circ$  and having properties similar to the polytopes used in Lemma 3.6.

Let us start with a simple two-dimensional case (which will not require  $K$  to be close to  $B_\infty^2$  and actually gives yet another solution to the Mahler conjecture in  $\mathbb{R}^2$ ):

**Two dimensional case.** Assume that  $B_\infty^2$  is a parallelogram of maximal area containing  $K$ . Then from Lemma 3.3 we get that  $\pm e_1, \pm e_2 \in K \cap B_\infty^2$ .

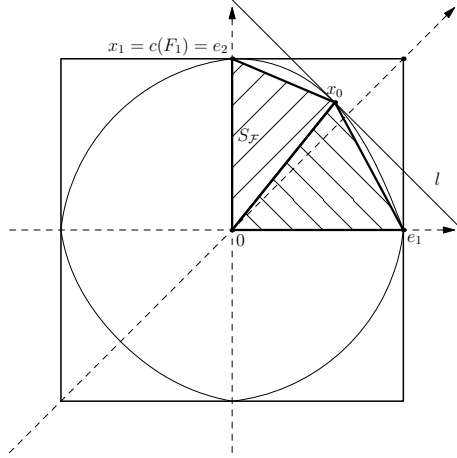

FIGURE 4. Construction of polytope  $P$ .

We will now construct polytopes  $P$  and  $P'$  "approximating"  $K$  and  $K^\circ$  respectively. Consider a flag of faces  $\mathcal{F} = \{F_0 \subset F_1\}$ , where  $F_1$  is just a side of  $B_\infty^2$  and  $F_0$  is one of the vertices belonging to  $F_1$ . Define  $x_1 = c(F_1) \in \{\pm e_1, \pm e_2\}$ . At first we construct a point  $x_0$  corresponding to  $F_0$ . Consider a tangent line  $l$  to  $K$  perpendicular to  $c(F_0)$ . Let  $x_0$  be a tangent point of  $l$  and  $K$  (see Figure 4). Notice that  $x_0$  and  $c(F_0)$  need

not to be parallel! This is why we make things look harder and do not immediately use notation of Lemma 3.6.

Let  $S_{\mathcal{F}} = \text{conv}\{0, x_0, x_1\}$  and

$$P = \bigcup_{\mathcal{F}} S_{\mathcal{F}},$$

where  $P$  is the union of all (eight) simplexes defined by flags of  $B_{\infty}^2$ . Notice that  $P \subset K$  and that in the two dimensional case  $P$  is convex (this will not be the case in higher dimension!). Now we will create  $P' \subset K^{\circ}$ . Again,  $P'$  will be the union of simplexes: as before, consider a flag of faces  $\mathcal{F}$  of  $B_{\infty}^2$ , also consider points  $x_0, x_1$ . Let  $x_i^*$  be a dual point to  $x_i$ . More precisely,  $x_i^*$  is parallel to the normal vector to  $K$  at point  $x_i$  and  $x_i \cdot x_i^* = 1$ . Thus,  $x_i^* \in K^{\circ}$ . We also note that  $x_i^* = x_1 \in \{\pm e_1, \pm e_2\}$  (see Figure 5).

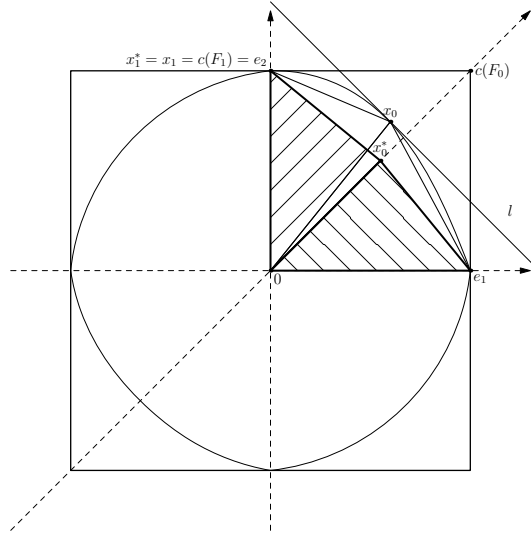

FIGURE 5. Construction of polytopes  $P$  and  $P'$ .

Let  $S'_{\mathcal{F}} = \text{conv}\{0, x_0^*, x_1^*\}$  and

$$P' = \bigcup_{\mathcal{F}} S'_{\mathcal{F}}.$$

By construction, we have that  $P \subset K$  and  $P' \subset K^{\circ}$  and thus  $\mathcal{P}(K) \geq |P||P'|$ . We could finish the proof if we would be able to apply Lemma 3.6 to  $P$  and  $P'$  as to  $Q$  and  $Q'$ . The only obstacle is that for each flag  $\mathcal{F}$  points  $x_0$  from above may not be parallel to  $c(F_0)$ ! (notice that  $x_0^*$  is in the right place). The solution is to move them! This reminds the original Mahler's proof of the two-dimensional case, see Theorem 3.2.

Indeed, moving those points along tangent line  $l$  will not change the volume of  $P$ . This follows from the simple observation described in Exercise 3.12: consider triangle  $ABC$ ; moving vertex  $C$  along the line parallel to  $AB$  would not change the area of the triangle. In our case we take  $C = x_0$  and  $A, B \in \{\pm e_1, \pm e_2\}$ , so that  $A, B$  are vertices of  $P$  adjacent to  $x_0$  and notice that the line  $l$  is parallel to  $AB$  (See Figure 6).

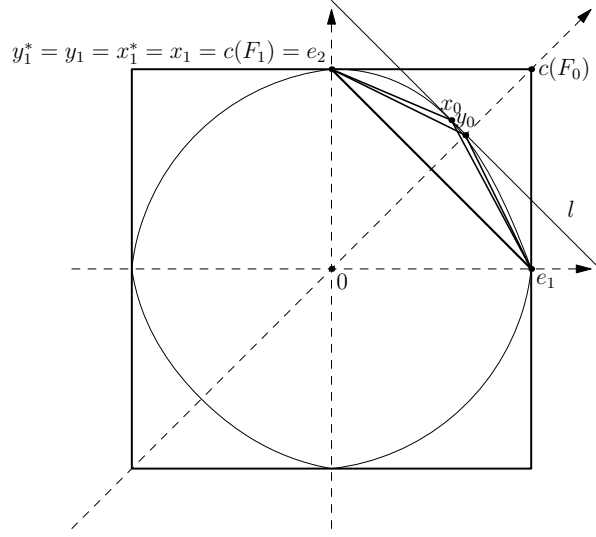

FIGURE 6. Moving  $x_0$  to  $y_0$  (triangle  $e_1, x_0, e_2$  to triangle  $e_1, y_0, e_2$ ).

Thus, we may move  $x_0$  to  $y_0$  which is the point of intersection of  $l$  and  $[0, c(F_0)]$ :

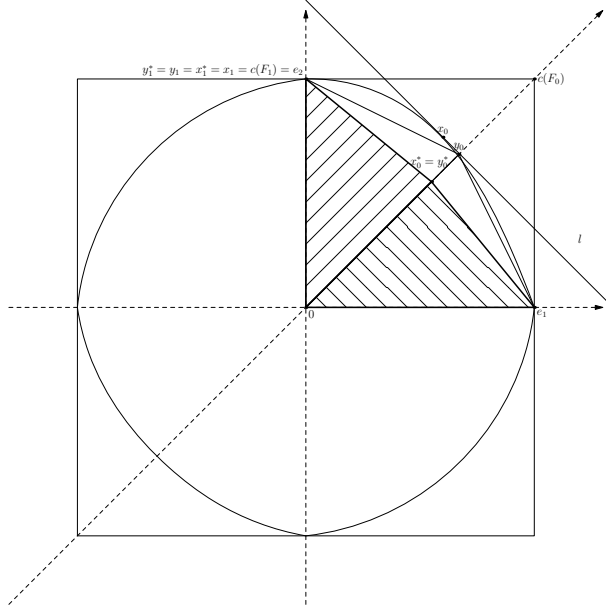

FIGURE 7. Now we have  $Q$  and  $Q'$  as in Lemma 3.6.

Note that this move does not change the position of  $x_0^*$ . Finally, we apply Lemma 3.6 with  $P' = Q'$  and  $Q$  is  $P$  with vertices  $x_0$  moved to  $y_0$  (see Figure 7). This concludes the proof of two-dimensional case.

The main difficulty of the case  $n > 2$  is that  $S_{\mathcal{F}}$  will have more than one vertices that needs to be moved and some of them will have to be moved not exactly parallel to the base. Now, to make a move and not to change the volume of  $P$  (and  $P'$ ) by much we are required to assume that  $K$  is close to  $B_{\infty}^n$ .

**General case.** We first outline the plan. We use Lemma 3.5 to get that  $\pm e_1, \dots, \pm e_n \in K \cap B_\infty^n$ . As before we need to select other points on the boundary of  $K$  and  $K^\circ$  and to construct two (not necessarily convex!) polytopes  $P \subset K$  and  $P' \subset K^\circ$  such that

$$|P||P'| \geq \mathcal{P}(B_\infty^n) - C\delta^2,$$

where  $\delta$  is the least positive number for which  $(1 - \delta)B_\infty^n \subset K$ . We conclude that  $B_\infty^n$  is a lower semi-stationary point for the volume product functional  $\mathcal{P}$ . This means that the perturbation of  $B_\infty^n$  by  $\delta$  in the Banach-Mazur distance may result in decreasing the product volume only by  $\delta^2$ , i.e., in the second order rather than in the first. Our last step is to show that either  $K$  contains a point outside  $(1 + c\delta)P$  or  $K^\circ$  contains a point outside  $(1 + c\delta)P'$  for some small positive  $c$ . This allows us to apply Lemma 3.4 to conclude that  $\mathcal{P}(K)$  exceeds  $|P||P'|$  by at least  $c\delta$  and get the final estimate

$$\mathcal{P}(K) \geq \mathcal{P}(B_\infty^n) + c\delta - C\delta^2$$

from which the strict local minimality follows immediately.

We first prove two lemmata which would allow us to move vertices of a simplex similarly as we did in the dimension 2. As before, given a set  $F \subset \mathbb{R}^n$ , we define  $\text{aff}(F)$  to be an affine subspace of minimal dimension containing  $F$ .

**Lemma 3.7.** *Let  $D \subset \mathbb{R}^n$  be a compact convex set with a non-empty interior, and let  $\dim(\text{aff}(D)) = n - 1$ . If  $f(x) = |\text{conv}(x, D)|$ , then  $\nabla f(x)$  is parallel to the unit normal vector  $\mathbf{n}_D$  of  $\text{aff}(D)$ .*

*Proof.* We can assume that  $D \subset \{y \in \mathbb{R}^n : y_n = 0\}$  and  $x_n > 0$ . Then

$$f(x) = x_n \frac{|D|}{n}, \quad \nabla f(x) = (0, \dots, 0, \frac{|D|}{n}).$$

□

It is clear that  $f(x) = f(y)$ , provided  $(x - y) \cdot \mathbf{n}_D = 0$ . The next lemma will allow us to move the vertices of the simplex along an affine hyperplane "almost" parallel to the base opposite to the moved vertex, so that the change in the volume is of the order  $\delta^2$ .

**Lemma 3.8.** *Let  $f$  be as above, and let  $\delta > 0$  be small enough. If  $|y - x| = O(\delta)$ , and  $|\mathbf{n}| = 1$  is such that  $|\mathbf{n} - \mathbf{n}_D| = O(\delta)$ ,  $(x - y) \cdot \mathbf{n} = 0$ , then  $|f(x) - f(y)| = O(\delta^2)$ .*

*Proof.* By the previous lemma,  $\nabla f(y)/|\nabla f(y)| = \mathbf{n}_D$ . Hence,

$$\begin{aligned} f(x) - f(y) &= |\nabla f(y)|(\mathbf{n}_D - \mathbf{n}) \cdot (x - y) + |\nabla f(y)|\mathbf{n} \cdot (x - y) + O(|x - y|^2) = \\ &|\nabla f(y)|(\mathbf{n}_D - \mathbf{n}) \cdot (x - y) + O(|x - y|^2). \end{aligned}$$

Applying the Cauchy-Schwartz inequality, we get the result. □

Next we will define the vertices of the polytopes  $P \subset K$  and  $P' \subset K^\circ$  and show that they can be moved to "the right place".

Let  $F$  be a face of  $B_\infty^n$  and  $F^* \subset B_1^n$  be a corresponding dual face (see Exercise 3.18). As before let  $c_F$  be a center of  $F$  and  $c_F^* = \frac{1}{n - \dim F} c_F$  be a center of  $F^*$ .

Let  $F^\perp = \{y \in \mathbb{R}^n : x \cdot y = 0, \text{ for all } x \in F\}$ , where  $\dim(F^\perp) = n - 1 - \dim(F)$ . Consider  $\alpha_F > 0$  such that  $\alpha_F c_F + F^\perp$  is tangent to  $K$ . We define  $x_F$  to be a corresponding

tangent point. We also set  $y_F = \alpha_F c_F$ . Notice that from  $(1 - \delta)B_\infty^n \subset K \subset B_\infty^n$  we get  $1 - \delta \leq \alpha_F \leq 1$ .

Now we switch to the dual face  $F^*$ . The same way as above, we define points  $x_F^*$  and  $y_F^* = \alpha_F^* c_F^*$  by replacing  $F$ ,  $K$  and  $B_\infty^n$  by  $F^*$ ,  $K^\circ$  and  $B_1^n$ , respectively. In Lemma 3.9 below we will present properties of  $x_F$ ,  $y_F$ ,  $x_F^*$  and  $y_F^*$  which are essential for our construction, but before let us suggest the following continuation of Exercise 3.18:

**Exercise 3.20.** *Let  $P \subset \mathbb{R}^n$  be a convex polytope such that  $0$  is an interior point of  $P$ . Consider a face  $F$  of  $P$  and the dual face  $F^*$  of  $P^\circ$ . Let  $l(F)$  be the linear subspace parallel to a face  $F$  of  $P$ , such that  $\dim(F) = \dim(l(F))$ . Prove the following relations:*

- $x \perp l(F^*)$ , for all  $x \in F$  and thus  $l(F^*) \subset F^\perp$ .
- $x^* \perp l(F)$ , for all  $x^* \in F^*$  and thus  $l(F) \subset (F^*)^\perp$ .
- $F^\perp = l(F^*)$ .
- $(F^*)^\perp = l(F)$ .
- $l(F) \perp l(F^*)$ .

**Lemma 3.9.** *Let  $F$  be a face of  $B_\infty^n$ . Suppose that  $(1 - \delta)B_\infty^n \subset K \subset B_\infty^n$ . Then*

- (1)  $(x_F - y_F) \perp c_F$  and  $(x_F^* - y_F^*) \perp c_F^*$ ,
- (2)  $x_F \cdot x_F^* = 1$  and  $y_F \cdot y_F^* = 1$ , (i.e.  $\alpha_F \alpha_F^* = 1$ ),
- (3)  $|x_F - y_F| = O(\delta)$  and  $|x_F^* - y_F^*| = O(\delta)$ .

*Proof.* We note that  $x_F = y_F + h_F$  and  $x_F^* = y_F^* + h_F^*$ , where  $h_F \in F^\perp$  and  $h_F^* \in (F^*)^\perp$ . Hence, (1) follows immediately from  $c_F \in F$  and  $c_F^* \in F^*$ .

Next we will prove (2). Consider a hyperplane  $H$  tangent to  $K$  at point  $x_F$ , note that  $\alpha_F c_F + F^\perp \subset H$ . Consider the point  $w$  "dual" to  $H$ , i.e. such that  $w \cdot z = 1$  for every  $z \in H$ . Thus,  $w \in \partial K^\circ$ . Also note that  $\alpha_F w \cdot u = 1$  for all  $u \in c_F + F^\perp$ . Using Exercise 3.9 and the fact that  $c_F$  is parallel to  $c_F^*$  we notice that

$$c_{F^*} + (F^*)^\perp = \{q \in \mathbb{R}^n : q \cdot u = 1, \forall u \in c_F + F^\perp\}.$$

This implies  $\alpha_F w \in c_{F^*} + (F^*)^\perp$ . Thus,  $w \in (\frac{1}{\alpha_F} c_{F^*} + (F^*)^\perp) \cap \partial K^\circ$ , which gives  $\alpha_F^* = 1/\alpha_F$ .

To prove (3) we denote by  $U$  a minimal subspace containing  $\alpha_F c_F + F^\perp$ . Then  $\dim U = \dim F^\perp + 1$  and  $B_\infty^n \cap U$  is a  $\dim U$ -dimensional unit cube with a vertex  $c_F$ . Thus, using the fact that the distance from  $\alpha_F c_F + F^\perp$  to  $c_F$  is  $O(\delta)$ , we get

$$|x_F - y_F| \leq \text{diam}((\alpha_F c_F + F^\perp) \cap B_\infty^n) = \text{diam}((\alpha_F c_F + F^\perp) \cap U \cap B_\infty^n) = O(\delta).$$

Similarly, using  $B_1^n \subset K^\circ \subset \frac{1}{1-\delta} B_1^n$  and  $\alpha_F^* = 1/\alpha_F$ , we get  $|x_F^* - y_F^*| = O(\delta)$ .  $\square$

**Remark 3.2.** *Notice that the estimate in (3) from Lemma 3.9 is exactly the reason why we used  $F^\perp$  and not the tangent hyperplane in order to define  $x_F$ .*

Consider a flag  $\mathcal{F} = \{F_0, F_1, \dots, F_{n-1}\}$  of faces of  $B_\infty^n$ . Since  $\pm e_j \in \partial K$  and  $\pm e_j \in \partial K^\circ$  (see Lemma 3.5), we will choose  $x_{F_{n-1}} = y_{F_{n-1}} = x_{F_{n-1}}^* = y_{F_{n-1}}^* = c_{F_{n-1}} = c_{F_{n-1}}^*$ .

For each other face  $F \in \mathcal{F}$ , we consider four points  $x_F$ ,  $x_F^*$ ,  $y_F$  and  $y_F^*$  defined in Lemma 3.9. These points induce the following four polytopes (in general, not convex!):

$$P = \cup_{\mathcal{F}} \text{conv}(0, x_{F_0}, \dots, x_{F_{n-1}}) \text{ and } P' = \cup_{\mathcal{F}} \text{conv}(0, x_{F_0}^*, \dots, x_{F_{n-1}}^*),$$

$$Q = \cup_{\mathcal{F}} \text{conv}(0, y_{F_0}, \dots, y_{F_{n-1}}) \text{ and } Q' = \cup_{\mathcal{F}} \text{conv}(0, y_{F_0}^*, \dots, y_{F_{n-1}}^*).$$

Thus, by Lemmata 3.9, 3.8 (applying them to each simplex in construction of  $P$  and  $P'$ ) we get

$$\|P\| - \|Q\| \leq C\delta^2 \text{ and } \|P'\| - \|Q'\| \leq C\delta^2,$$

whence, by Lemma 3.6

$$(23) \quad |P||P'| \geq |Q||Q'| - C\delta^2 \geq \mathcal{P}(B_\infty^n) - C\delta^2.$$

To prove the theorem we need to show that there is a reasonable gap in volumes of  $K$  and  $P$  or in volumes of  $K^\circ$  and  $P'$ , more precisely

$$(24) \quad |K| \geq |P| + c'\delta \text{ or } |K^\circ| \geq |P'| + c'\delta, \text{ for some } c' > 0.$$

Indeed, (24) together with (23) yields

$$\mathcal{P}(K) \geq \mathcal{P}(B_\infty^n) + c''\delta - C\delta^2 > \mathcal{P}(B_\infty^n),$$

provided that  $\delta > 0$  is small enough.

Since  $K \supset P$  and  $K^\circ \supset P'$ , to prove (24) we need to show that for some  $c > 0$ , either  $K \not\subset (1 + c\delta)P$ , or  $K^\circ \not\subset (1 + c\delta)P'$ . Then, by Lemma 3.4, we will get (24).

**The conclusion of the proof:** Note that at least one of the coordinates of one of the  $x_{\tilde{F}}$ , where  $\tilde{F}$  is a vertex of  $B_\infty^n$ , is at most  $1 - \delta$ . Indeed, assume that all coordinates are greater than  $(1 - \delta')$  in absolute value with some  $0 < \delta' < \delta$ . Define  $D = \text{conv}\{x_F : F \text{ is a vertex of } B_\infty^n\} \subset K$ . Consider  $z \in D^*$ , then  $1 \geq x_F \cdot z$  for all vertices  $F$ . Choose the vertex  $F$  so that  $(x_F)_j z_j \geq 0$  for all  $j = 1, \dots, n$ . Then,

$$1 \geq x_F \cdot z \geq (1 - \delta') \sum_j |z_j|.$$

Thus,  $D^* \subset (1 - \delta')^{-1}B_1^n$  and  $D \supset (1 - \delta')B_\infty^n$ , contradicting the minimality of  $\delta$ .

Due to symmetry, we may assume without loss of generality that  $\tilde{F} = (1, \dots, 1)$  and that  $(x_{\tilde{F}})_1 \leq 1 - \delta$ . Let us now explain the idea of the next construction. Note that, as we mentioned above, if  $K \not\subset (1 + c\delta)P$ , then there is a gap of volume  $c\delta$  between  $K$  and  $P$  (see Figure 8).

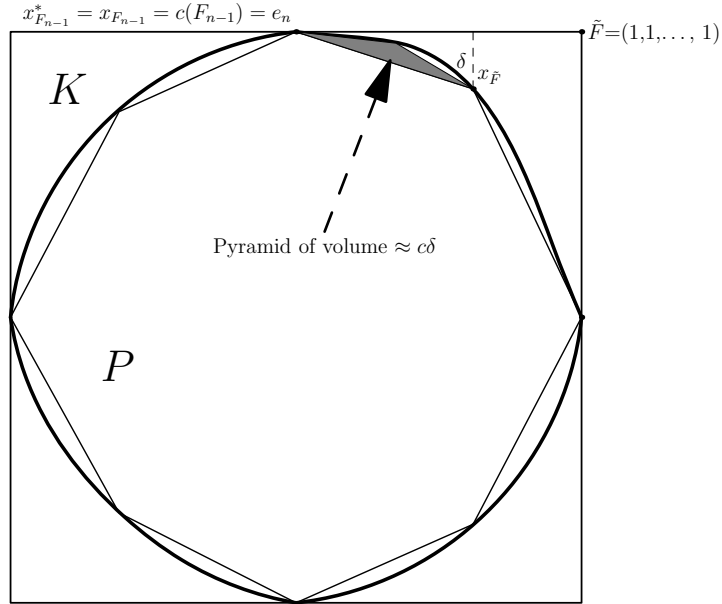

FIGURE 8.  $K \not\subset (1 + c\delta)P$ .

Thus we need to consider the case  $K \subset (1 + c\delta)P$  and to show that there is a  $c\delta$ -gap between the volumes of  $K^\circ$  and  $P'$ . In this case we notice that  $K$  is close to  $P$  and thus has a part of the boundary which "looks like" a face of  $P$ . Such a part, containing  $x_{\tilde{F}}$ , will produce a dual point which belongs to  $K^\circ$  but "far" from  $P'$  (see Figure 9).

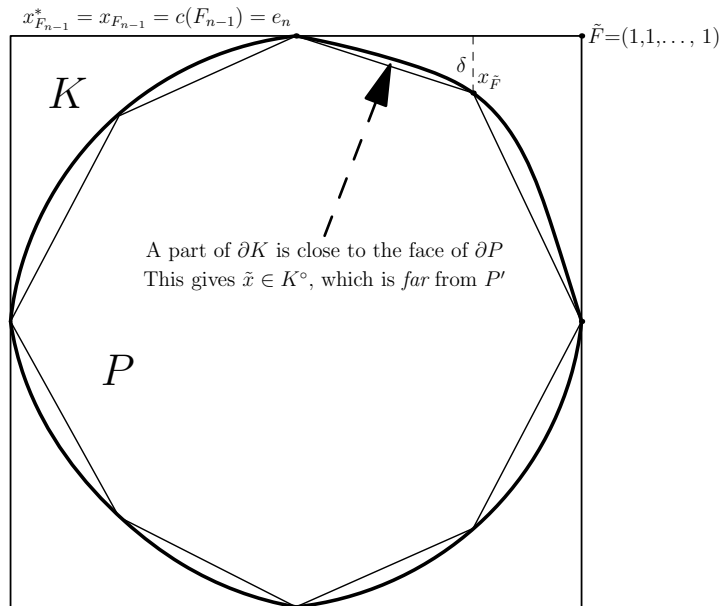

FIGURE 9.  $K \subset (1 + c\delta)P$ .

Now we are ready to present a detailed proof. Assume that

$$K \subset (1 + c\delta)P, \text{ and thus } \frac{1}{1 + c\delta}P^\circ \subset K^\circ.$$

We will now find a point  $\tilde{x}$  such that  $\tilde{x} \in K^\circ$  but  $\tilde{x} \notin (1 + c\delta)P'$ .

We will consider  $\tilde{x}$  to be a point "close" to vertex  $(1, 0, \dots, 0)$  of  $B_1^n$ . More precisely, let  $\tilde{x} = (1 - \delta, c'\delta, \dots, c'\delta)$ , where  $c' = 1/(n - \frac{5}{4})$ . Then  $\tilde{x} \in (1 - c''\delta)P^\circ$ , where  $c'' = 1/(4n - 5)$ . Indeed, it is enough to check that  $\tilde{x} \cdot x_F \leq 1 - c''\delta$  for all vertices  $x_F$  of  $P$ . If  $F \neq (1, \dots, 1)$ , then all coordinates of  $x_F$  do not exceed 1 and at least one does not exceed  $1/2$  (otherwise,  $x_F$  will be too far from  $F$ ). Thus, if  $\delta$  is small enough, we get

$$\tilde{x} \cdot x_F \leq (1 - \delta) + (n - 2)c'\delta + \frac{c'\delta}{2} = 1 - \delta + (n - \frac{3}{2})c'\delta = 1 - c''\delta.$$

If  $F$  has the vertex  $(1, \dots, 1)$ , then

$$\tilde{x} \cdot x_F \leq (1 - \delta)^2 + (n - 1)c'\delta = 1 - 2\delta + \frac{n - 1}{n - \frac{5}{4}}\delta + \delta^2 \leq 1 - 2\delta + \frac{4}{3}\delta + \delta^2 \leq 1 - c''\delta,$$

provided that  $\delta > 0$  is small enough. Therefore if  $c < c''$ , we get

$$\tilde{x} \in (1 - c''\delta)P^\circ \subset \frac{1}{1 + c\delta}P^\circ \subset K^\circ.$$

Now we will show that we may select  $c$  small enough such that  $\tilde{x} \notin (1 + c\delta)P'$ . Note that for every  $x \in P'$ , we have

$$|x_1| + (1 - C'\delta) \sum_{j \geq 2} |x_j| \leq 1,$$

provided  $C'$  is chosen large enough. Indeed, again it is enough to check this for the vertices  $x_F^*$  of  $P'$ . From  $P' \subset K^\circ \subset \frac{1}{1 - \delta}B_1^n$  we get that

$$\sum_{j \geq 1} |(x_F^*)_j| \leq 1 + C\delta.$$

If  $c_F \neq (\pm 1, 0, \dots, 0)$  we have  $\sum_{j \geq 2} |(x_F^*)_j| \geq 1/3$ , so

$$|(x_F^*)_1| + (1 - C'\delta) \sum_{j \geq 2} |(x_F^*)_j| \leq \sum_{j \geq 1} |(x_F^*)_j| - C'\delta \sum_{j \geq 2} |(x_F^*)_j| \leq 1 + C\delta - \frac{C'\delta}{3} \leq 1,$$

provided that  $C' \geq 3C$ . If  $c_F = (\pm 1, 0, \dots, 0)$ , then  $x_F = \pm e_1$  and the inequality is trivial.

Now it remains to note that

$$|\tilde{x}_1| + (1 - C'\delta) \sum_{j \geq 2} |\tilde{x}_j| = 1 - \delta + (1 - C'\delta)(n - 1)c'\delta = 1 + c''\delta - C'(n - 1)c'\delta^2 > 1 + c\delta,$$

provided that  $c < c''/2$  and  $\delta$  is small enough, whence  $\tilde{x} \notin (1 + c\delta)P'$ .

**Remark 3.3.** *It was shown in Lemma 3.2 and Exercise 3.15 that Hanner polytopes have the same volume product as the cube. Recently, Jaegil Kim [K] proved that any Hanner polytope is a local minimizer for  $\mathcal{P}(K)$ .*

#### 4. ZONONDS AND ZONOTOPES

**Definition 4.1.** A Minkowski sum of line segments in  $\mathbb{R}^n$  is called a zonotope, i.e. a symmetric convex body  $Z \subset \mathbb{R}^n$  is a zonotope if there exists a set of segments  $\{[-v_i, v_i]\}_{i=1}^m \subset \mathbb{R}^n$ , such that

$$Z = \sum_{i=1}^m [-v_i, v_i].$$

Zonoid is a limit of zonotopes in Hausdorff metric.

**Exercise 4.1.** Show that any face of a zonotope is again a zonotope and thus must be symmetric. (**Hint:** See [Bl], [Sc2].)

**Exercise 4.2.** Show that a projection of a zonotope (zonoid) is again a zonotope (zonoid).

**Exercise 4.3.** Show that any symmetric polygon in  $\mathbb{R}^2$  is a zonotope (and thus any symmetric convex body in  $\mathbb{R}^2$  is a zonoid). We will give a Harmonic Analysis proof of this fact later, (see Corollary 5.1).

Assume that  $\alpha_i = |v_i| > 0$  and define  $u_i = v_i/|v_i| \in \mathbb{S}^{n-1}$ . Then, from the definition and the properties of the support function we get

$$h_Z(x) = \sum_{i=1}^m h_{[-v_i, v_i]}(x) = \sum_{i=1}^m \alpha_i |x \cdot u_i|.$$

Taking the limit we obtain

**Lemma 4.1.**  $Z$  is a zonoid iff there exists an even measure  $\mu$  (called the generating measure of  $Z$ ) on  $\mathbb{S}^{n-1}$  such that

$$h_Z(x) = \int_{\mathbb{S}^{n-1}} |x \cdot u| d\mu(u).$$

**Exercise 4.4.** Check which of  $B_p^n$ ,  $p \geq 1$ , are zonoids:

- Show that  $B_\infty^n$  is a zonoid.
- Show that  $B_2^n$  is a zonoid.
- Show that  $B_1^n$  is not a zonotope for  $n \geq 3$ .
- Show that a zonotope is a linear image of  $B_\infty^N$ , for  $N$  big enough.
- Show that a polytope  $P$  is the polar of a zonoid if and only if it is a central section of  $B_1^N$ , for  $N$  big enough.
- It is also true that  $B_p^n$  is a zonoid for any  $p \geq 2$  and not a zonoid for any  $p \in [1, 2)$  and  $n \geq 3$ , but this fact requires a non-trivial use of Harmonic Analysis, see [K5].

Lemma 4.1 allows us to give a quite useful formula for the volume of zonoids. Indeed, from Theorem 2.3 we get

$$\begin{aligned} |Z| &= \frac{1}{n} \int_{\mathbb{S}^{n-1}} h_Z(\theta) dS(Z, \theta) = \frac{1}{n} \int_{\mathbb{S}^{n-1}} \int_{\mathbb{S}^{n-1}} |\xi \cdot \theta| d\mu(\xi) dS(Z, \theta) \\ &= \frac{1}{n} \int_{\mathbb{S}^{n-1}} \int_{\mathbb{S}^{n-1}} |\xi \cdot \theta| dS(Z, \theta) d\mu(\xi) = \frac{2}{n} \int_{\mathbb{S}^{n-1}} |Z| \xi^\perp | d\mu(\xi). \end{aligned}$$

**Lemma 4.2.** *Let  $Z \subset \mathbb{R}^n$  be a zonoid with the generating measure  $\mu$ , then*

$$|Z| = \frac{2}{n} \int_{\mathbb{S}^{n-1}} |Z|\xi^\perp| d\mu(\xi).$$

Now we present an example of the application of Lemma 4.2. The Shephard problem [Shep] can be stated as follows. Let  $K, L$  be convex symmetric bodies in  $\mathbb{R}^n$  such that

$$(25) \quad |K|\xi^\perp| \leq |L|\xi^\perp|, \text{ for all } \xi \in \mathbb{S}^{n-1}.$$

Does it follow that

$$|K| \leq |L|?$$

**Theorem 4.1.** (*Shephard problem - Affirmative case [Sc1]*). *Consider convex symmetric bodies  $K$  and  $L$  in  $\mathbb{R}^n$  which satisfy the condition (25). In addition assume that  $L$  is a zonoid, then  $|K| \leq |L|$ .*

*Proof.* Let  $\mu$  be the generating measure of  $L$ . Then

$$(26) \quad \int_{\mathbb{S}^{n-1}} |K|\xi^\perp| d\mu \leq \int_{\mathbb{S}^{n-1}} |L|\xi^\perp| d\mu.$$

From Lemma 4.2 we see that the right hand side of the above inequality is just  $\frac{n}{2}|L|$ . Thus, we need to work on the left hand side:

$$\int_{\mathbb{S}^{n-1}} |K|\xi^\perp| d\mu = \frac{1}{2} \int_{\mathbb{S}^{n-1}} \int_{\mathbb{S}^{n-1}} |\xi \cdot \theta| dS(K, \theta) d\mu(\xi) = \frac{1}{2} \int_{\mathbb{S}^{n-1}} h_L(\theta) dS(K, \theta) = \frac{n}{2} V_1(K, L),$$

and we got that (26) is equivalent to

$$V_1(K, L) \leq |L|.$$

Now we apply the first Minkowski inequity (Corollary 2.3) to finish the proof.  $\square$

Theorem 4.1 together with Exercise 4.3 gives an affirmative answer to the Shephard problem in  $\mathbb{R}^2$ .

**Exercise 4.5.** *Give a direct solution of the Shephard problem in  $\mathbb{R}^2$ .*

**Exercise 4.6.** *Show that the answer to the Shephard problem is negative (even in  $\mathbb{R}^2$ ) if we drop the symmetry assumption.*

**Exercise 4.7.** *Show that the Shephard problem has a negative answer in  $\mathbb{R}^n$ ,  $n \geq 3$ .*

**Hint:** *Consider bodies of revolution, take  $K = B_2^n$  and  $L$  to be a rotation of a square around its diagonal. To construct a counterexample, make a suitable transformation to  $L$  so that  $K$  and  $L$  satisfy (25) but  $|K| > |L|$ .*

**Exercise 4.8.** *Show that if  $K, L \subset \mathbb{R}^n$  are convex bodies such that they satisfy the condition (25), then  $|\partial K| \leq |\partial L|$ .*

The Busemann-Petty problem (the section analog of the Shephard problem) asks a similar question for sections of convex symmetric bodies. In this case the answer is affirmative for  $n < 5$  and negative starting from dimension 5 (see [K5]).

**Exercise 4.9.** Show that if  $L$  is a star-shaped body such that

$$|B_2^n \cap \xi^\perp| \leq |L \cap \xi^\perp|, \text{ for all } \xi \in \mathbb{S}^{n-1},$$

then  $|B_2^n| \leq |L|$ .

**Open Problem 4.1.** Let  $K, L$ , be convex symmetric bodies in  $\mathbb{R}^n$ ,  $n \geq 5$ . Assume that

$$|K| |\xi^\perp| \leq |L| |\xi^\perp| \text{ and } |K \cap \xi^\perp| \leq |L \cap \xi^\perp|, \text{ for all } \xi \in \mathbb{S}^{n-1}.$$

Is it true that  $|K| \leq |L|$ ?

**4.1. Mahler conjecture: case of zonoids.** In this section we give an affirmative answer to the Mahler conjecture in the special case of zonoids.

**Theorem 4.2.** (*S. Reisner, [R1]*) Let  $Z \subset \mathbb{R}^n$  be a zonoid, then

$$\mathcal{P}(Z) \geq \mathcal{P}(B_\infty^n).$$

We will present the proof from [GMR], we will start with the following lemmata

**Lemma 4.3.** Let  $Z$  be a zonoid in  $\mathbb{R}^n$  with the generating measure  $\mu$ . Then

$$(n+1)|Z| \int_{\mathbb{S}^{n-1}} \left[ \int_{Z^\circ} |x \cdot y| dy \right] d\mu(x) = 2|Z^\circ| \int_{\mathbb{S}^{n-1}} |Z|x^\perp| d\mu(x),$$

in particular, for some  $x_0 \in \mathbb{S}^{n-1}$  we have

$$(n+1)|Z| \int_{Z^\circ} |x_0 \cdot y| dy \geq 2|Z^\circ| |Z|x_0^\perp|.$$

*Proof.* We use Fubini theorem to see that

$$\begin{aligned} \int_{\mathbb{S}^{n-1}} \left[ \int_{Z^\circ} |x \cdot y| dy \right] d\mu(x) &= \int_{Z^\circ} \left[ \int_{\mathbb{S}^{n-1}} |x \cdot y| d\mu(x) \right] dy = \int_{Z^\circ} h_Z(y) dy = \int_{Z^\circ} \|y\|_{Z^\circ} dy \\ &= \int_{\mathbb{S}^{n-1}} \|\theta\|_{Z^\circ} \int_0^{\|\theta\|_{Z^\circ}^{-1}} r^n d\theta = \frac{1}{n+1} \int_{\mathbb{S}^{n-1}} \|\theta\|_{Z^\circ}^{-n} d\theta = \frac{n}{n+1} |Z^\circ|. \end{aligned}$$

To finish the proof we multiply the last equality by the volume formula for  $Z$  (see Lemma 4.2).  $\square$

**Lemma 4.4.** Let  $f : \mathbb{R}^+ \rightarrow \mathbb{R}^+$  satisfy  $f(0) = 1$ ,  $\int_0^\infty f(x) dx > 0$  and for some  $p > 0$ ,  $f^{1/p}$  is concave on the support of  $f$ . Then

$$\int_0^\infty t f(t) dt \leq \frac{p+1}{p+2} \left[ \int_0^\infty f(t) dt \right]^2.$$

*Proof.* Let  $a > 0$  be such that

$$\int_0^\infty f(t)dt = \int_0^\infty (1 - at)_+^p dt = \frac{1}{a(p+1)}.$$

Let  $g(x) = f(x) - (1 - ax)_+^p$ . Since  $g(0) = 0$ ,  $\int g(x)dx = 0$ , and  $f^{1/p}$  is concave, there exists a point  $x_0 \in \mathbb{R}^+$  such that  $g(x) \geq 0$  for  $x \in [0, x_0]$  and  $g(x) \leq 0$ , for  $x \geq x_0$ . Thus,

$$\int_x^\infty g(x) \leq 0 \text{ for all } x \in \mathbb{R}^+,$$

and

$$\begin{aligned} \int_0^\infty tf(t)dt &= \int_0^\infty \int_x^\infty f(t)dt dx \leq \int_0^\infty \int_x^\infty (1 - at)_+^p dt dx \\ &= \frac{1}{(p+1)(p+2)a^2} = \frac{p+1}{p+2} \left[ \int_0^\infty f(t)dt \right]^2. \end{aligned}$$

□

**Lemma 4.5.** *Let  $K$  be a convex symmetric body in  $\mathbb{R}^n$ . Then*

$$\int_K |x \cdot y| dy \leq \frac{n}{2(n+1)} \frac{|K|^2}{|K \cap x^\perp|}, \text{ for all } x \in \mathbb{S}^{n-1}.$$

*Proof.* Consider the section function  $A_{K,\xi}(t) = |K \cap \{\xi^\perp + t\xi\}|$  (see Definition 2.3). Then by Fubini theorem,

$$\int_K |x \cdot y| dy = 2 \int_0^\infty t A_{K,\xi}(t) dt \text{ and } |K| = 2 \int_0^\infty A_{K,\xi}(t) dt.$$

Moreover, applying Corollary 2.1 we get that  $A_{K,\xi}^{1/(n-1)}(t)$  is concave on its support. We finish the proof by applying Lemma 4.4 with  $f = A_{K,\xi}(t)/A_{K,\xi}(0)$  and  $p = n - 1$ . □

*Proof.* We will prove Theorem 4.2 by induction. The Mahler conjecture is true in  $\mathbb{R}$ . Let  $Z$  be a zonoid in  $\mathbb{R}^n$ . By Lemmata 4.3 and 4.5 we get that for some  $x_0 \in \mathbb{S}^{n-1}$ :

$$|Z^\circ| |Z|x_0^\perp| \leq \frac{n+1}{2} |Z| \int_{Z^\circ} |x_0 \cdot y| dy \leq \frac{n}{4} \frac{|Z| |Z^\circ|^2}{|Z^\circ \cap x_0^\perp|}.$$

Simplifying the above inequality we get

$$|Z^\circ \cap x_0^\perp| |Z|x_0^\perp| \leq \frac{n}{4} |Z| |Z^\circ|.$$

Using the fact that the projection of a zonoid is again a zonoid and applying (3) from Lemma 3.1 together with the induction hypothesis we get

$$|Z||Z^\circ| \geq \frac{4}{n}|(Z|x_0^\perp)^\circ||Z|x_0^\perp| \geq \frac{4^n}{n!}.$$

□

**Remark 4.1.** Notice that Exercise 4.3 together with Theorem 4.2 gives, yet another, affirmative solution to the Mahler conjecture in  $\mathbb{R}^2$ .

## 5. RADON AND COSINE TRANSFORMS

We have already met the Radon and the Cosine transforms in previous sections, when we defined the volumes of projections and sections. Here we would like to give formal definitions and provide the reader with very useful formulas connecting those transforms to the Fourier Transform of distributions.

**Definition 5.1.** Let  $\phi$  be an integrable function on  $\mathbb{R}^n$ , which is also integrable on every hyperplane. The **Radon Transform** of  $\phi$  is defined as a function of hyperplane  $H(\xi, t) = \{x \in \mathbb{R}^n : x \cdot \xi = t\}$ , where  $\xi \in \mathbb{R}^n$  and  $t \in \mathbb{R}$ :

$$R\phi(\xi, t) = \int_{H(\xi, t)} \phi(x) dx.$$

The **Spherical Radon transform**  $\mathcal{R} : C(\mathbb{S}^{n-1}) \rightarrow C(\mathbb{S}^{n-1})$  is defined by

$$\mathcal{R}f(\xi) = \int_{\mathbb{S}^{n-1} \cap \xi^\perp} f(\theta) d\theta.$$

Finally, the **Cosine transform**  $\text{Cos} : C(\mathbb{S}^{n-1}) \rightarrow C(\mathbb{S}^{n-1})$  is defined by

$$\text{Cos}f(\xi) = \int_{\mathbb{S}^{n-1}} |\theta \cdot \xi| f(\theta) d\theta.$$

**Exercise 5.1.** Show that

$$A_{K, \xi}(0) = |K \cap \xi^\perp| = \frac{1}{n-1} \mathcal{R}(\|\cdot\|_K^{-n+1})(\xi).$$

Also prove that if  $K$  is convex and smooth enough then,

$$|K|_{\xi^\perp} = \frac{1}{2} \text{Cos}(f_K)(\xi),$$

where  $f_K$  is the curvature function of  $K$  (see Definition 2.6).

The next lemma shows that Spherical Radon and Cosine transforms are self-adjoint:

**Lemma 5.1.** For functions  $f, g \in C(\mathbb{S}^{n-1})$ :

$$\begin{aligned} \int_{\mathbb{S}^{n-1}} \text{Cos}f(\xi)g(\xi)d\xi &= \int_{\mathbb{S}^{n-1}} f(\xi)\text{Cos}g(\xi)d\xi, \\ \int_{\mathbb{S}^{n-1}} \mathcal{R}f(\xi)g(\xi)d\xi &= \int_{\mathbb{S}^{n-1}} f(\xi)\mathcal{R}g(\xi)d\xi, \end{aligned}$$

*Proof.* The self-adjointness of the Spherical Cosine transform follows immediately from the Fubini theorem. The self-adjointness of the Spherical Radon transform is not so straightforward. One can prove it by noticing that uniformly in  $\xi$

$$\mathcal{R}f(\xi) = \lim_{\varepsilon \rightarrow 0} \frac{1}{2\varepsilon} \int_{\mathbb{S}^{n-1} \cap \{|\theta \cdot \xi| \leq \varepsilon\}} f(\theta) d\theta.$$

□

The following lemma connects the regular Radon transform to the Fourier transform. It will help us in the future to link the Spherical Radon and Cosine transforms to the Fourier transform of distributions.

**Lemma 5.2.** *Let  $\phi \in L_1(\mathbb{R}^n)$ . Then*

$$\widehat{R\phi(\xi, t)}(z) = \hat{\phi}(z\xi), \text{ for all } z \in \mathbb{R}, \xi \in \mathbb{R}^n,$$

where  $\hat{\phi}$  is  $n$ -dimensional Fourier transform of  $\phi$  and  $\widehat{R\phi(\xi, t)}(z)$  is the one-dimensional Fourier transform of the function  $R\phi(\xi, t)$  with respect to  $t \in \mathbb{R}$ .

*Proof.* By Fubini Theorem,

$$\hat{\phi}(z\xi) = \int_{\mathbb{R}^n} \phi(x) e^{-iz(x \cdot \xi)} dx = \int_{\mathbb{R}} e^{-izt} \left( \int_{\xi \cdot x = t} \phi(x) dx \right) dt = \widehat{R\phi(\xi, t)}(z).$$

□

We denote by  $\mathcal{S}$  the space of rapidly decreasing infinitely differentiable functions (test functions) on  $\mathbb{R}^n$  with values in  $\mathbb{C}$ . By  $\mathcal{S}'$  we denote the space of distributions over  $\mathcal{S}$ . Every locally integrable real valued function  $f$  on  $\mathbb{R}^n$  with power growth at infinity represents a distribution acting by integration: for every  $\phi \in \mathcal{S}$ ,

$$\langle f, \phi \rangle = \int_{\mathbb{R}^n} f(x) \phi(x) dx.$$

The Fourier transform of a distribution  $f$  is defined by

$$\langle \hat{f}, \hat{\phi} \rangle = (2\pi)^n \langle f, \phi \rangle,$$

for every test function  $\phi$ .

We refer the reader to the books by Rudin [Ru] and Gelfand and Shilov [GS] for details about distributions.

The next Lemma is the link between the Spherical Radon transform and the Fourier transform of distributions:

**Lemma 5.3.** *Let  $f$  be an even homogeneous of degree  $-n + 1$  function, continuous on  $\mathbb{R}^n \setminus \{0\}$ . Then the Fourier transform of  $f$  is an even homogeneous function of degree  $-1$ , continuous on  $\mathbb{R}^n \setminus \{0\}$ , whose restriction to the sphere equals*

$$\mathcal{R}f(\xi) = \frac{1}{\pi} \hat{f}(\xi) \forall \xi \in \mathbb{S}^{n-1}.$$

*Proof.* Since  $f$  is even, it is enough to consider only even test functions  $\phi \in \mathcal{S}$ :

$$\langle \hat{f}, \phi \rangle = \langle f, \hat{\phi} \rangle = \int_{\mathbb{R}^n} f(x) \hat{\phi}(x) dx = \int_{\mathbb{S}^{n-1}} f(\theta) \left( \int_0^\infty \hat{\phi}(t\theta) dt \right) d\theta.$$

Next we notice that (since  $\phi$  even):

$$\int_0^\infty \hat{\phi}(t\theta) dt = \frac{1}{2} \int_{-\infty}^\infty \hat{\phi}(t\theta) dt = \frac{1}{2} \left[ \hat{\phi}(t\theta) \right]_t^\wedge (0) = \pi \int_{\{x \in \mathbb{R}^n: x \cdot \theta = 0\}} \phi(x) dx = (*),$$

where the third equality follows from Lemma 5.2. Next, passing to the polar coordinates in  $\theta^\perp$ , we get

$$(*) = \pi \int_{\mathbb{S}^{n-1} \cap \theta^\perp} \int_0^\infty r^{n-2} \phi(r\xi) dr d\xi = \mathcal{R} \left[ \int_0^\infty r^{n-2} \phi(r\xi) dr \right] (\theta).$$

Thus, applying Lemma 5.1 we get

$$\langle \hat{f}, \phi \rangle = \pi \int_{\mathbb{S}^{n-1}} \mathcal{R} f(\xi) \left( \int_0^\infty r^{n-2} \phi(r\xi) dr \right) d\xi = \pi \int_{\mathbb{R}^n} |x|_2^{-1} \mathcal{R} f \left( \frac{x}{|x|} \right) \phi(x) dx.$$

□

The following two theorems are immediate corollaries of Lemma 5.3:

**Theorem 5.1.** *Consider a symmetric, star-shaped body  $K \subset \mathbb{R}^n$ , then*

$$|K \cap \xi^\perp| = \frac{1}{\pi(n-1)} (\|\cdot\|_K^{-n+1})^\wedge(\xi).$$

**Theorem 5.2. (Minkowski's uniqueness Theorem).** *Let  $K$  and  $L$  be origin-symmetric star-shaped bodies in  $\mathbb{R}^n$  such that for all  $\theta \in \mathbb{S}^{n-1}$*

$$|K \cap \theta^\perp| = |L \cap \theta^\perp|.$$

*Then  $K = L$ .*

**Exercise 5.2.** *Consider a positive even continuous function  $f : \mathbb{R}^n \rightarrow \mathbb{R}$ . Let  $K, L \subset \mathbb{R}^n$  be origin-symmetric star-shaped bodies such that for all  $\theta \in \mathbb{S}^{n-1}$*

$$\int_{K \cap \theta^\perp} f(x) dx = \int_{L \cap \theta^\perp} f(x) dx.$$

*Then  $K = L$ . Hint: see [Z].*

Observe that Theorem 5.1 yields  $(\|\cdot\|_K^{-n+1})^\wedge(\xi) = \pi(n-1)A_{K,\xi}(0)$ . This fact can be generalized to the Fourier transform of the general powers of the norming functional:

**Theorem 5.3.** *Let  $D$  be an origin-symmetric convex infinitely smooth body in  $\mathbb{R}^n$ . Then  $\forall \xi \in \mathbb{S}^{n-1}$  and  $k \in \mathbb{N}$ ,  $k \neq n-1$ ,*

$$(27) \quad \|\cdot\|_{\widehat{D}^{-n+k+1}}(\xi) = (-1)^{k/2} \pi(n-k-1) A_{D,\xi}^{(k)}(0),$$

when  $k$  is even, and

(28)

$$\|\cdot\|_{\widehat{D}^{-n+k+1}}(\xi) = (-1)^{\frac{k+1}{2}} 2(n-k-1)k! \int_0^\infty \frac{A_{D,\xi}(z) - A_{D,\xi}(0) - \dots - A_{D,\xi}^{(k-1)}(0) \frac{z^{k-1}}{(k-1)!}}{z^{k+1}} dz,$$

when  $k$  is odd.

The proof of the above Theorem 5.3 can be found in [K5] and [KY].

A slightly more complicated but similar technique is needed to produce a Fourier type formula for the Cosine transform. We consider test functions supported outside of the origin, for which  $\langle r^{-2}, \phi(r\xi) \rangle = \int_{\mathbb{R}} r^{-2} \phi(r\xi) dr$ .

If  $\mu$  is absolutely continuous with the density  $g \in L_1(\mathbb{S}^{n-1})$ , we define the extension  $g(x)$ ,  $x \in \mathbb{R}^n \setminus \{0\}$ , as a homogeneous function of degree  $-n-1$ :  $g(x) = |x|^{-n-1}g(x/|x|)$ , and identify  $\widehat{\mu}_e$  with  $\widehat{g}$ .

The following fact is the Cosine transform analog of Lemma 5.3, (for the proof see [K5]):

**Lemma 5.4.** *For every  $\theta \in \mathbb{S}^{n-1}$ ,*

$$\widehat{\mu}_e(\theta) = -\frac{\pi}{2} \int_{\mathbb{S}^{n-1}} |\theta \cdot y| d\mu(y) = -\frac{\pi}{2} \text{Cos} \mu(\theta).$$

*In particular, if  $\mu$  is absolutely continuous with the density  $g \in L_1(\mathbb{S}^{n-1})$ , then*

$$\widehat{g}(\theta) = -\frac{\pi}{2} \text{Cos} g(\theta).$$

**Remark 5.1.** *Lemma 5.4 helps to invert the Cosine transform. Indeed, since the Fourier transform is self-inverting for even functions (up to constant  $(2\pi)^n$ ), one has*

$$(29) \quad \text{Cos}^{-1} f(\theta) = -\frac{\pi}{2} \frac{1}{(2\pi)^n} \widehat{f}(\theta).$$

The above Lemma 5.4 and Theorem 2.3 give the following result (see [KRZ]):

**Theorem 5.4.** *Let  $L$  be a convex origin symmetric body in  $\mathbb{R}^n$ . Then*

$$\widehat{S_e(L, \cdot)}(\theta) = -\pi \text{Vol}_{n-1} \left( L|_{\theta^\perp} \right), \quad \forall \theta \in \mathbb{S}^{n-1}.$$

*In particular, if the body  $L$  has a curvature function  $f_L$  then*

$$\widehat{f_L}(\theta) = -\pi \text{Vol}_{n-1} \left( L|_{\theta^\perp} \right), \quad \forall \theta \in \mathbb{S}^{n-1}.$$

The next theorem is a projection version of Theorem 5.2. The first step in the proof is the use of Theorem 5.4. But it requires an additional step which is quite involved. This step guarantees that from  $S(K, \cdot) = S(L, \cdot)$  we get  $K = L$ , (we refer to [Sc2] for the detailed proof).

**Theorem 5.5. (Alexandrov uniqueness Theorem).** *Let  $K$  and  $L$  be origin-symmetric convex bodies in  $\mathbb{R}^n$  such that for all  $\theta \in \mathbb{S}^{n-1}$*

$$|K|_{\theta^\perp}| = |L|_{\theta^\perp}|.$$

*Then  $K = L$ .*

**Open Problem 5.1.** Let  $\gamma_n(A) = (2\pi)^{-n/2} \int_A e^{-|x|^2/2} dx$  be a standard Gaussian measure. Consider two, convex symmetric bodies  $K, L \subset \mathbb{R}^n$  such that for all  $\theta \in \mathbb{S}^{n-1}$

$$\gamma_{n-1}(K|\theta^\perp) = \gamma_{n-1}(L|\theta^\perp).$$

Is it true that then  $K = L$ ?

Lemma 5.4 and the Remark after it give the Fourier analytic characterization of Zonoids:

**Theorem 5.6.** An origin symmetric convex body  $L$  in  $\mathbb{R}^n$  is zonoid if and only if there exists a measure  $\mu$  on  $\mathbb{S}^{n-1}$  so that

$$(30) \quad \widehat{h}_L = -\mu_e.$$

Now we are ready to provide the reader with a link connecting the Fourier transform of the support function of a Zonoid to the section function of its dual.

Suppose that an origin symmetric convex body  $L \subset \mathbb{R}^n$  has the property that  $h_L$  is an infinitely differentiable function on the sphere  $\mathbb{S}^{n-1}$ . This, in particular, means that the polar body  $L^\circ$  is infinitely smooth (recall that  $h_L = \|\cdot\|_{L^\circ}$ ). Putting  $k = n$ ,  $D = L^\circ$  in Theorem 5.3, we get:

**Theorem 5.7.** Consider an infinitely smooth convex symmetric body  $L \subset \mathbb{R}^n$ . Then, for every  $\xi \in \mathbb{S}^{n-1}$ ,

$$(31) \quad \widehat{h}_L(\xi) = (-1)^{1+n/2} \pi A_{L^\circ, \xi}^{(n)}(0), \text{ provided } n \text{ is even,}$$

$$(32) \quad \widehat{h}_L(\xi) = (-1)^{(n-1)/2} 2n! \int_0^\infty \frac{A_{L^\circ, \xi}(z) - A_{L^\circ, \xi}(0) - \dots - A_{L^\circ, \xi}^{(n-1)}(0) \frac{z^{n-1}}{(n-1)!}}{z^{n+1}} dz,$$

provided  $n$  is odd.

The next result (from [KRZ]) gives the characterization of zonoids in terms of the sections of the polar body.

**Theorem 5.8.** Let  $L$  be an origin symmetric convex body in  $\mathbb{R}^n$  so that  $h_L$  is infinitely differentiable on  $\mathbb{S}^{n-1}$ . The body  $L$  is a zonoid if and only if for every  $\xi \in \mathbb{S}^{n-1}$ ,

(i) if  $n$  is even

$$(-1)^{n/2} A_{L^\circ, \xi}^{(n)}(0) \geq 0;$$

(ii) if  $n$  is odd

$$(-1)^{(n+1)/2} \int_0^\infty \frac{A_{L^\circ, \xi}(z) - A_{L^\circ, \xi}(0) - \dots - A_{L^\circ, \xi}^{(n-1)}(0) \frac{z^{n-1}}{(n-1)!}}{z^{n+1}} dz \geq 0.$$

**Corollary 5.1.** Every symmetric convex body in  $\mathbb{R}^2$  is a zonoid.

*Proof.* We will prove the Corollary only in the case of an infinitely smooth body  $L \subset \mathbb{R}^2$ . We use Theorem 5.8 with  $n = 2$  to get that symmetric convex body  $L$  in  $\mathbb{R}^2$  is a zonoid if and only if

$$A_{L^\circ, \xi}''(0) \leq 0.$$

But by Brunn's theorem (Corollary 2.1), the central section has the maximal volume among all hyperplane sections perpendicular to a fixed direction. Therefore, for every  $\xi$  the function  $A_\xi$  has maximum at zero and  $A''_{L^*,\xi}(0) \leq 0$ .  $\square$

**Exercise 5.3.** Use Theorem 5.8 to show that there are convex symmetric bodies in  $\mathbb{R}^n$ ,  $n \geq 3$ , which are not zonoids. **Hint:** To construct  $L^\circ$ , consider a body of revolution, for example rotate function  $f$  around direction  $x_1$ . Notice that you need to find only one "bad" direction, i.e. you do not need to compute  $A_{L^\circ,\xi}(z)$  for all directions  $\xi$ . Computing  $A_{L^\circ,e_1}(z)$  is not hard and you may select a proper function  $f$  to get a negative sign in Theorem 5.8. Also note that using a perturbation argument, we may always assume that  $L$  is infinitely smooth with positive Gaussian curvature.

## 6. LOCAL AND EQUATORIAL CHARACTERIZATIONS OF ZONOIDS

As we discussed in the previous section, there exist convex symmetric bodies in  $\mathbb{R}^n$ ,  $n \geq 3$ , which are not zonoids. It is quite an interesting question of how to decide if the given body is a zonoid or not. The next lemma (see [Sc2]) gives an interesting geometric characterization for Zonotopes:

**Lemma 6.1.** *A convex polytope is a zonotope if and only if all of its two-dimensional faces are centrally symmetric.*

It is natural to ask if Lemma 6.1 can be generalized to the case of zonoids, i.e. can a zonoid be determined from local information? This question was posed repeatedly (see [Sc2] for the history of the problem), however, W. Weil showed [W] that a *local* characterization of zonoids does not exist. In particular, he showed that *there exists an origin-symmetric convex  $C^\infty$ -smooth body  $K \subset \mathbb{R}^n$ ,  $n \geq 3$ , that is not a zonoid but has the following property: for each  $u \in \mathbb{S}^{n-1}$  there exists a zonoid  $Z_u$  with center at the origin and a neighborhood  $U_u \subset \mathbb{S}^{n-1}$  of  $u$  such that the boundaries of  $K$  and  $Z_u$  coincide at all points where the exterior unit normal vectors belong to  $U_u$ .*

Thus, no characterization of zonoids that involves only arbitrarily small neighborhoods of boundary points is possible. We will present a proof of this result in section 6.3.

**Exercise 6.1.** *Show that zonotopes can be locally characterized: Consider a polytope  $P \subset \mathbb{R}^n$  such that for each  $u \in \mathbb{S}^{n-1}$  there exists a zonotope  $Z_u$  with center at the origin and a neighborhood  $U_u \subset \mathbb{S}^{n-1}$  of  $u$  such that the boundaries of  $P$  and  $Z_u$  coincide at all points where the exterior unit normal vectors belong to  $U_u$ . Prove that  $P$  is a zonotope.*

**Exercise 6.2.** *Consider a body  $K \subset \mathbb{R}^n$ , such that for any point  $u \in \mathbb{S}^{n-1}$  there exists an Ellipsoid  $E_u$  a neighborhood  $U_u \subset \mathbb{S}^{n-1}$  of  $u$  such that the boundaries of  $K$  and  $E_u$  coincide at all points where the exterior unit normal vectors belong to  $E_u$ . Prove that  $K$  is an Ellipsoid.*

In 1977, W. Weil (see [W]) proposed the following conjecture about **local equatorial** characterization of zonoids. *Let  $L \subset \mathbb{R}^n$  be an origin-symmetric convex body and assume that for any equator  $\sigma \subset \mathbb{S}^{n-1}$ , there exists a zonoid  $Z_\sigma$  and a neighborhood  $E_\sigma$  of  $\sigma$  such that the boundaries of  $L$  and  $Z_\sigma$  coincide at all points where the exterior unit vector belongs to  $E_\sigma$ ; then  $L$  is a zonoid.*

**Exercise 6.3.** Show that the local equatorial characterization naturally arises from the following property of zonotopes: Consider a zonotope  $Z = \sum_{i=1}^m [-v_i, v_i]$ , and  $S$  be one of  $[-v_i, v_i]$ . Also consider the equator  $E_S = \{u \in \mathbb{S}^{n-1} : u \perp S\}$ . Prove that each support set

$$F(Z, u) = \{x \in Z : h_Z(u) = x \cdot u\} = \text{Facet of } Z \text{ with normal vector } u,$$

where  $u \in E_S$  contains a translate of  $S$ .

Conclude that  $\bigcup_{u \in E_S} F(Z, u)$  makes up a zone in  $\partial Z$ . This explains the name "zonotope".

Affirmative answers for *even* dimensions were given independently by Panina [Pan] in 1988 and Goodey and Weil [GW] in 1993.

Finally, it was proved in [NRZ] using the Fourier Analytic approach (via Theorem 5.8) that the answer to the conjecture in *odd* dimensions is *negative*.

In this section we will describe the solution for Local and Local equatorial characterizations. Let us start with the following example which was proposed by F. Nazarov (see [Schl]):

**6.1. A motivating example.** Why there should be no local characterization of Zonoids?

**Exercise 6.4.** Let  $f \in L_1([-\pi, \pi])$  be a real valued, even,  $2\pi$ -periodic function that "locally" coincides with a function having non-negative Fourier coefficients. Is it true that  $f$  has non-negative Fourier coefficients?

**Solution:** We remind that

$$\hat{f}(j) = \frac{1}{2\pi} \int_{-\pi}^{\pi} f(t) e^{-ijt} dt \text{ for each } j \in \mathbb{Z}.$$

We are given that  $f$  is such that for all  $x \in [-\pi, \pi]$  there exists  $\epsilon > 0$  and a  $2\pi$ -periodic, real valued, even function  $g_x \in L_1([-\pi, \pi])$  such that

- $\hat{g}_x(j) \geq 0$  for all  $j \in \mathbb{Z}$ ;
- $g_x \equiv f$  on  $U_\epsilon(x) = (x - \epsilon, x + \epsilon) \cap [-\pi, \pi]$ .

So the question is whether  $\hat{f}(j) \geq 0$  for all  $j \in \mathbb{Z}$ .

One can easily see the parallel between this question and the aforementioned question about characterization of zonoids. We claim that there exists a  $2\pi$ -periodic real valued, even function  $f \in L_1([-\pi, \pi])$  that "locally" has non-negative Fourier coefficients but actually has at least one negative Fourier coefficient.

The idea is to start with a  $2\pi$ -periodic, even, real valued function  $g$ , supported around zero, having positive Fourier coefficients and then to perturb it.

A classical example of a localized function with all non-negative Fourier coefficients would be a  $\delta_0$  measure, or "functional" version of it, Fejer type kernel. In our case we take  $g(t)$  such that  $g(t) = 0$  for  $|t| \in [\pi/4, \pi]$  and  $g(t) = -\frac{4}{\pi}|t| + 1$  for  $|t| \in [0, \pi/4]$ .

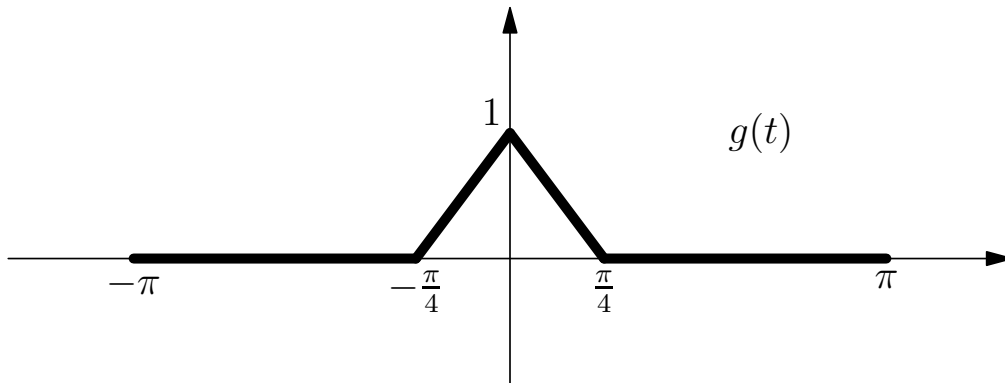

Observe that  $\hat{g}(j) = \frac{1}{\pi} \int_0^{\pi/4} (-\frac{4}{\pi}t \cos jt + \cos jt) dt = \frac{4}{\pi^2 j^2} (1 - \cos \frac{\pi}{4}j)$ .

Now we define our function  $f$  as a perturbation of  $g$ ,  $f = g(t) + \alpha(t)$  for  $t \in [-\pi, \pi]$ , where  $\alpha(t) = \sin(2|t|)$  for  $|t| \in [\pi/2, \pi]$  and  $\alpha(t) = 0$  otherwise.

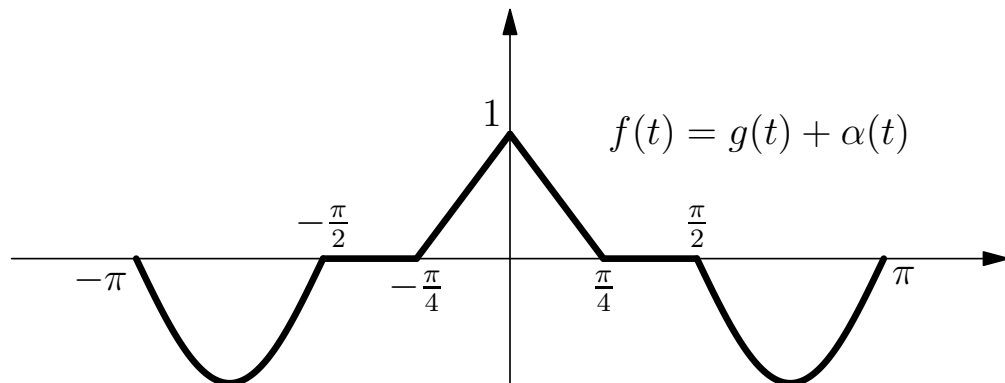

Notice that,  $\hat{f}(0) = \int_{-\pi}^{\pi} f(t) dt < 0$ .

We have to show that  $f$  coincides locally with functions having all non-negative Fourier coefficients. Fix any  $x \in [-\pi, \pi]$ . If  $|x| < \pi/2$ , then take  $\varepsilon > 0$  such that  $U_\varepsilon(x) \subset [-\pi/2, \pi/2]$  and take  $g_x(t) = g(t)$ , clearly,  $g_x(t) = f(t)$  for  $t \in U_\varepsilon(x)$ . Next, consider  $|x| \in [\pi/2, \pi]$ . In this case we choose  $\varepsilon = \pi/4$  and "add  $\delta_0$ -measure to  $f(t)$ ":  $g_x(t) = bg(t) + \alpha(t)$ ,

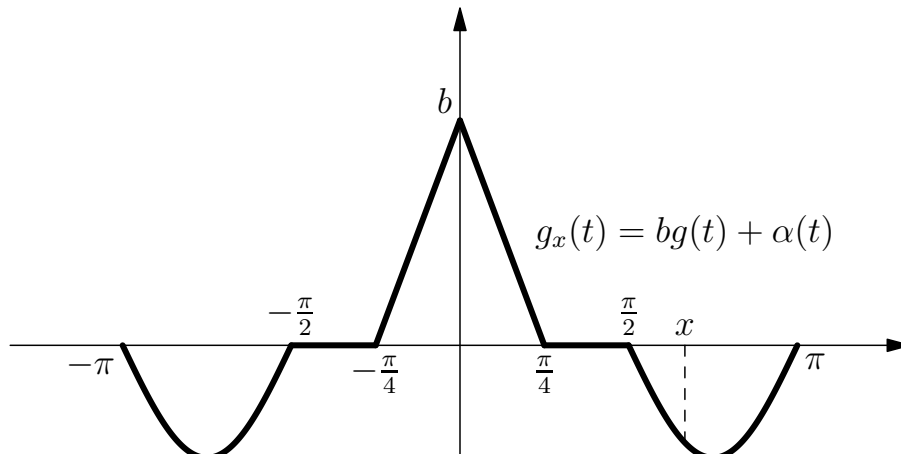

where  $b$  is selected large enough so that  $\hat{g}_x(j) \geq 0$  for all  $j \in \mathbb{Z}$ . Again,  $g_x(t) = f(t)$  for  $t \in U_\varepsilon(x)$ , this finishes the construction.

**6.2. Local equatorial characterization.** For  $0 < \varepsilon < 1$  and  $\xi \in \mathbb{S}^{n-1}$ , we denote by  $U_\varepsilon(\xi)$  the union of caps centered at  $\xi$  and  $-\xi$ ,

$$U_\varepsilon(\xi) := \{\theta \in \mathbb{S}^{n-1} : |\theta \cdot \xi| \geq \sqrt{1 - \varepsilon^2}\}.$$

We denote by  $E_\varepsilon(\xi)$ ,  $0 < \varepsilon < 1$ , the neighborhood of the equator  $\mathbb{S}^{n-1} \cap \xi^\perp$ :

$$E_\varepsilon(\xi) := \{\theta \in \mathbb{S}^{n-1} : |\theta \cdot \xi| < \varepsilon\}.$$

We see from Theorem 5.8 that for  $n$  even, the characterization of zonoids is defined in properties by the properties of the derivatives of the section function  $A_{L^\circ, \xi}(0)$ , i.e. around the equator  $\mathbb{S}^{n-1} \cap \xi^\perp$ . This gives:

**Theorem 6.1.** *Let  $n$  be even and let  $L \subset \mathbb{R}^n$  be an origin-symmetric convex body such that  $h_L$  is infinitely smooth. Assume that for any great sphere  $\xi^\perp \cap \mathbb{S}^{n-1}$ , there exists a zonoid  $Z_\xi$  and a neighborhood  $E_{\varepsilon(\xi)}(\xi)$  of  $\xi^\perp \cap \mathbb{S}^{n-1}$  such that the boundaries of  $K$  and  $Z_\xi$  coincide at all points where the exterior unit vector belong to  $E_{\varepsilon(\xi)}(\xi)$ ; then  $L$  is a zonoid.*

To prove the Theorem in the general case, one can use the reasons which are similar to those described in [NRZ], Section 5.

Again, studying statement of Theorem 5.8 for  $n$  odd, we see that zonoids depend on the global properties of the function  $A_{L^\circ, \xi}(t)$ . This will be the main idea for a construction a counterexample. We will need the following lemmata:

**Lemma 6.2.** *Let  $n \geq 3$  be odd. Then  $\exists c > 0$  such that  $\forall \varepsilon > 0$  small enough and for any fixed  $x, \xi \in \mathbb{S}^{n-1}$ , there exists an even function  $f_{x, \xi}$  on  $\mathbb{S}^{n-1}$  such that  $f_{x, \xi} = 0$  on  $E_\varepsilon(x)$ , but  $\text{Cos}^{-1} f_{x, \xi} \geq c > 0$  on  $U_\varepsilon(\xi)$ .*

*Proof.* First, we fix  $x, \xi \in \mathbb{S}^{n-1}$  and find  $\varepsilon = \varepsilon(x, \xi)$  and  $c = c(x, \xi)$  satisfying the requirements of the lemma. Then, we use a compactness argument to produce absolute  $\varepsilon$  and  $c$ .

For fixed  $x, \xi \in \mathbb{S}^{n-1}$  and some small  $\varepsilon > 0$  there exist two infinitely smooth symmetric star bodies  $M, Q$ , such that  $\|\cdot\|_M = \|\cdot\|_Q$  on the closure of  $E_\varepsilon(\xi) \cup E_\varepsilon(x)$ , and  $\|\cdot\|_M > \|\cdot\|_Q$  otherwise (thus  $Q \subset M$ ). Set  $f_{x, \xi}(\cdot) = (-1)^{\frac{n+1}{2}} (\|\cdot\|_M - \|\cdot\|_Q)$ .

Then  $f_{x, \xi}$  is an even infinitely differentiable function such that  $f_{x, \xi} = 0$  on  $E_\varepsilon(x)$ . Also  $\|\cdot\|_M = \|\cdot\|_Q$  on  $E_\varepsilon(\xi)$  implies  $A_{M, \xi}^{(k)}(0) = A_{Q, \xi}^{(k)}(0)$ ,  $k = 0, 1, \dots, n-1$  because differentiability at zero is a local property. Thus, by Lemma 5.4, the Remark after it, and Theorem 5.3, we get

$$\begin{aligned} \text{Cos}^{-1} f_{x, \xi}(\xi) &= (-1)^{\frac{n+1}{2}} [\text{Cos}^{-1}(\|\cdot\|_M)(\xi) - \text{Cos}^{-1}(\|\cdot\|_Q)(\xi)] \\ &= -(-1)^{\frac{n+1}{2}} c_n (\widehat{\|\cdot\|_M}(\xi) - \widehat{\|\cdot\|_Q}(\xi)) \\ (33) \quad &= c'_n \int_0^\infty \frac{A_{M, \xi}(z) - A_{Q, \xi}(z)}{z^{n+1}} dz, \text{ where } c_n, c'_n > 0. \end{aligned}$$

The integral in the last line is strictly positive. Indeed  $A_{Q, \xi} = A_{M, \xi}$  near zero and  $A_{M, \xi} > A_{Q, \xi}$  elsewhere on the union of their supports because the boundaries of  $Q$  and  $M$

agree on  $E_\varepsilon(\xi)$  and  $Q \subsetneq M$ . Hence the integral is strictly positive. So, we have exhibited that for fixed  $x, \xi \in \mathbb{S}^{n-1}$  there exists  $\varepsilon' = \varepsilon'(x, \xi) > 0$  and  $c' = c'(x, \xi)$  such that there exists an even function  $f_{x, \xi}$  satisfying  $f_{x, \xi} = 0$  on  $E_\varepsilon(x)$ , and  $\mathcal{C}os^{-1}f_{x, \xi}(\xi) \geq c' > 0$ .

The function  $\mathcal{C}os^{-1}f_{x, \xi}$  is continuous on  $\mathbb{S}^{n-1}$  since  $M, Q$  are infinitely smooth. Hence,  $\mathcal{C}os^{-1}f_{x, \xi} \geq c > 0$  on  $U_{\varepsilon''}(\xi)$ , for some  $\varepsilon'' > 0$  and  $c = c(x, \xi)$ . Put  $\tilde{\varepsilon} = \tilde{\varepsilon}(x, \xi) = \min(\varepsilon', \varepsilon'')$ . We proved that for any  $x$  and  $\xi$ , there is  $\tilde{\varepsilon} = \tilde{\varepsilon}(x, \xi) > 0$  and a function  $f_{x, \xi}$  such that  $f_{x, \xi} = 0$  on  $E_{\tilde{\varepsilon}}(x)$ , but  $\mathcal{C}os^{-1}f_{x, \xi} \geq c$  on  $U_{\tilde{\varepsilon}}(\xi)$ ,  $c = c(x, \xi)$ .

Now we use the compactness argument to show that we can choose  $\varepsilon$  and  $c$  independent of  $x$  and  $\xi$ . We choose a finite set of pairs  $\{x_i, \xi_i\}_{i=1}^m$  such that  $\{U_{\tilde{\varepsilon}_i/2}(x_i) \times U_{\tilde{\varepsilon}_i/2}(\xi_i)\}_{i=1}^m$  cover  $\mathbb{S}^{n-1} \times \mathbb{S}^{n-1}$ . We take

$$\varepsilon = \frac{1}{2} \min_{1 \leq i \leq m} \tilde{\varepsilon}_i \text{ and } c = \min_{1 \leq i \leq m} c(x_i, \xi_i).$$

Then, for any  $(x, \xi)$ , there is a pair  $(x_i, \xi_i)$  such that  $(x, \xi) \in U_{\tilde{\varepsilon}_i/2}(x_i) \times U_{\tilde{\varepsilon}_i/2}(\xi_i)$  and thereby

$$E_\varepsilon(x) \times U_\varepsilon(\xi) \subset E_{\tilde{\varepsilon}_i}(x_i) \times U_{\tilde{\varepsilon}_i}(\xi_i).$$

Finally, we may define  $f_{x, \xi} = f_{x_i, \xi_i}$ . □

**Remark 6.1.** Note that dilating  $M$  and  $Q$  (and thus functions  $f_{x, \xi}$ ) we may assume that  $c$  is as large as we want. By the technical reasons we take  $c = 2\mathcal{C}os^{-1}\mathbf{1}$ . Moreover, we can assume that the set of functions  $\{f_{x, \xi}\}_{x, \xi \in \mathbb{S}^{n-1}}$  in the lemma is finite.

**Lemma 6.3.** Let  $n \geq 3$ . For any point  $\xi_0 \in \mathbb{S}^{n-1}$  there exists a zonoid  $\tilde{K} \in C_+^\infty$  such that  $\mathcal{C}os^{-1}h_{\tilde{K}}(\xi)$  is strictly positive for all  $\xi \neq \pm\xi_0$ , and  $\mathcal{C}os^{-1}h_{\tilde{K}}(\pm\xi_0) = 0$ .

*Proof.* Fix  $n \geq 3$ . Then there exists convex symmetric body  $M \subset \mathbb{R}^n$  which is  $C^\infty$  smooth and with positive curvature such that  $\mathcal{C}os^{-1}h_M$  is sign-changing (see Exercise 5.3 or [K5], page 161, for a construction of a such non-zonoid body).

For  $t \in [0, 1]$  consider the Minkowski sum  $K(t) = tB_2^n + (1-t)M$ . Then  $h_{K(t)} = th_{B_2^n} + (1-t)h_M$  is a  $C^\infty$ -function,  $\mathcal{C}os^{-1}h_{K(0)}(\xi)$  is sign-changing and there exists  $\Lambda' \subset \mathbb{S}^{n-1}$  such that  $\mathcal{C}os^{-1}h_{K(0)}(\xi) < 0, \forall \xi \in \Lambda'$ . On the other hand,  $\mathcal{C}os^{-1}h_{K(1)}(\xi) > 0, \forall \xi \in \mathbb{S}^{n-1}$ . The map  $t \rightarrow \mathcal{C}os^{-1}h_{K(t)}$  is continuous, since  $\mathcal{C}os$  is a continuous bijection of  $C^\infty(\mathbb{S}^{n-1})$  into itself, ([Ga2], page 381). Hence, there is  $t_0 \in [0, 1]$  such that

$$\mathcal{C}os^{-1}h_{K(t_0)} \geq 0, \quad \text{and} \quad \mathcal{C}os^{-1}h_{K(t_0)}(\xi) = 0, \forall \xi \in \Lambda \subset \mathbb{S}^{n-1}$$

and some  $\Lambda \neq \emptyset$ . Fix any  $\xi_0 \in \Lambda$ . Consider an even  $C^\infty$  smooth function  $g$  on  $\mathbb{S}^{n-1}$  such that

$$g(x) > 0, \forall x \neq \pm\xi_0 \text{ and } g(\pm\xi_0) = 0.$$

For  $\varepsilon > 0$  define a body  $\tilde{K}$ :

$$\mathcal{C}os^{-1}h_{\tilde{K}}(\xi) = \mathcal{C}os^{-1}h_{K(t_0)}(\xi) + \varepsilon g(\xi).$$

Note that  $\mathcal{C}os^{-1}h_{\tilde{K}}(\xi)$  is strictly positive for all  $\xi \neq \pm\xi_0$ , and  $\mathcal{C}os^{-1}h_{\tilde{K}}(\pm\xi_0) = 0$ . Moreover,

$$h_{\tilde{K}} = h_{K(t_0)} + \varepsilon \mathcal{C}os g.$$

Since  $\mathcal{C}os g$  is a continuous function and  $K(t_0) \in C_+^\infty$ , we may choose  $\varepsilon$  small enough so that  $\tilde{K} \in C_+^\infty$ . Using the rotation argument, we can take  $\xi_0$  to be arbitrary. □

**Theorem 6.2.** *Let  $n \geq 3$  be odd. There exists  $\varepsilon > 0$  and a convex body  $K$  which is not a zonoid, but nevertheless  $\forall x \in \mathbb{S}^{n-1}$  there exists a zonoid  $L_x$  such that  $h_K = h_{L_x}$  on  $E_\varepsilon(x)$ .*

*Proof.* We define a convex body  $K$  and a family of convex bodies  $\{L_x\}_{x \in \mathbb{S}^{n-1}}$  using the zonoid  $\tilde{K}$  and functions  $f_{x, \xi_0}$  from Lemma 6.2. We fix some small  $\varepsilon$  satisfying the requirements of Lemma 6.2 with  $c = 2\mathcal{C}os^{-1}\mathbf{1}$  (see Remark after Lemma 6.2). Then, define  $K = K_{\delta, \xi_0}$  via  $h_K = h_{\tilde{K}} - \delta$ , where for the moment  $\delta > 0$  is assumed to be so small that  $\tilde{K} \in C_+^\infty$  and  $\mathcal{C}os^{-1}h_K$  is strictly positive outside  $U_\varepsilon(\xi_0)$ . Note that  $\mathcal{C}os^{-1}h_K(\xi_0) < 0$  and thus  $K$  is not a zonoid.

Now we define a family of convex bodies  $\{L_x\}_{x \in \mathbb{S}^{n-1}}$ . Since  $\tilde{K} \in C_+^\infty$ , we take  $\delta$  so small that  $h_{L_x} := h_{\tilde{K}} - \delta + \delta f_{x, \xi_0} > 0$  on  $\mathbb{S}^{n-1}$  and  $L_x$  is convex. Observe that  $h_{L_x} = h_K$  on  $E_\varepsilon(x)$  for any  $x \in \mathbb{S}^{n-1}$ .

We can assume that  $\delta$  is so small that

$$\mathcal{C}os^{-1}h_{L_x} = \mathcal{C}os^{-1}h_{\tilde{K}} - \delta\mathcal{C}os^{-1}\mathbf{1} + \delta\mathcal{C}os^{-1}f_{x, \xi_0} > 0$$

on  $\mathbb{S}^{n-1} \setminus U_\varepsilon(\xi_0)$ , since  $\mathcal{C}os^{-1}h_{\tilde{K}} > 0$  on  $\mathbb{S}^{n-1} \setminus U_\varepsilon(\xi_0)$ .

To show that bodies  $L_x$  are zonoids  $\forall x \in \mathbb{S}^{n-1}$ , it is enough to prove that  $\mathcal{C}os^{-1}h_{L_x} > 0$  on  $U_\varepsilon(\xi_0)$ . By the Remark after Lemma 6.2,  $\min_{x \in \mathbb{S}^{n-1}} \mathcal{C}os^{-1}f_{x, \xi_0} > 2\mathcal{C}os^{-1}\mathbf{1}$  on  $U_\varepsilon(\xi_0)$ , hence

$$\mathcal{C}os^{-1}h_{L_x} = \mathcal{C}os^{-1}h_{\tilde{K}} - \delta\mathcal{C}os^{-1}\mathbf{1} + \delta\mathcal{C}os^{-1}f_{x, \xi_0} \geq \delta\mathcal{C}os^{-1}\mathbf{1} > 0$$

on  $U_\varepsilon(\xi_0)$ , and the result follows.  $\square$

**Open Problem 6.1.** *What is the smallest  $\varepsilon > 0$  we should choose in order to obtain an affirmative answer to Weyl's question on the local equatorial characterization? Is it possible to take  $\varepsilon$  slightly smaller than  $1/2$ ?*

**6.3. Local characterization.** In this section we prove the result of W. Weil [W] for zonoids. Our proof is different from the one of W. Weil and follows [NRZ]. We show that, given  $x, \xi \in \mathbb{S}^{n-1}$ , one can construct a function  $f$  which is zero around  $x$ , but such that the inverse Cosine transform of  $f$  is positive around  $\xi$ . Notice that if the dimension is odd, since there is no local equatorial characterization of zonoids, there cannot be a local characterization of zonoids. For convenience of the reader we split the proof of this result (compare Lemma 6.8 with Lemma 6.2) into four statements. We will use the following notation

$$\mathfrak{S}_{\varepsilon, x} = \{f \in C^\infty(\mathbb{S}^{n-1}) \text{ even} : f = 0 \text{ on } U_\varepsilon(x)\}, \quad 0 < \varepsilon < 1.$$

**Lemma 6.4.**  *$\mathcal{C}os^{-1}$  commutes with rotations. That is  $\mathcal{C}os^{-1}(f \circ \rho) \equiv (\mathcal{C}os^{-1}f) \circ \rho$  for all  $f \in C^\infty(\mathbb{S}^{n-1})$  and for all  $\rho \in SO(n)$ .*

**Lemma 6.5.** *Let  $n \geq 3$ , and let  $\xi, x \in \mathbb{S}^{n-1}$  be two orthogonal vectors. Assume that any  $f \in \mathfrak{S}_{1/4, x}$  satisfies  $\mathcal{C}os^{-1}f(\xi) = 0$ . Then for any pair of orthogonal vectors  $u, v \in \mathbb{S}^{n-1}$  we have  $f \in \mathfrak{S}_{1/4, u}$  implies  $\mathcal{C}os^{-1}f(v) = 0$ .*

*Proof.* For any two pairs of orthogonal unit vectors  $(\xi, x)$ ,  $(u, v)$  there exists a rotation  $\rho \in SO(n)$  satisfying  $u = \rho(x), v = \rho(\xi)$ . Since  $\mathcal{C}os^{-1}$  commutes with rotations, the result follows.  $\square$

**Lemma 6.6.** *Let  $n \geq 3$ , and let  $\xi \in x^\perp$ . Assume that any  $f \in \mathfrak{S}_{1/4,x}$  satisfies  $\mathcal{C}os^{-1}f(\xi) = 0$ . Then  $\mathcal{C}os^{-1}(\mathfrak{S}_{1/2,x}) \subset \mathfrak{S}_{1/4,\xi}$ .*

*Proof.* Take any  $u \in U_{1/4}(\xi)$ . Let  $\rho \in SO(n)$ ,  $\rho(\xi) = u$ , where  $\xi$  is rotated into  $u$  inside  $U_{1/4}(\xi)$  in the plane containing  $\xi, u$  and the origin. Then  $\rho(x) \in U_{1/4}(x)$ , and  $\mathfrak{S}_{1/2,x} \subset \mathfrak{S}_{1/4,\rho(x)}$ . Moreover,  $\mathcal{C}os^{-1}f(u) = 0$  since  $\mathcal{C}os^{-1}$  commutes with rotations. The point  $u$  was chosen arbitrarily in  $U_{1/4}(\xi)$ , hence  $\mathcal{C}os^{-1}(\mathfrak{S}_{1/2,x}) \subset \mathfrak{S}_{1/4,\xi}$ .  $\square$

**Lemma 6.7.** *Let  $n \geq 3$ , and let  $\xi \in x^\perp$ . Then there exists a function  $f = f_{x,\xi}$  on  $\mathbb{S}^{n-1}$  satisfying  $f_{x,\xi} = 0$  on  $U_{1/4}(x)$ , but  $\mathcal{C}os^{-1}f_{x,\xi}(\xi) \neq 0$ .*

*Proof.* Assume the contrary. Then  $\mathcal{C}os^{-1}(\mathfrak{S}_{1/2,x}) \subset \mathfrak{S}_{1/4,\xi}$  by Lemma 6.6. Take any vector  $y \in \mathbb{S}^{n-1}$ , and find a vector  $q \in x^\perp \cap y^\perp$ . Let  $\rho \in SO(n)$  be such that  $\rho(x) = x$ ,  $\rho(\xi) = q$ . Observe that  $f \in \mathfrak{S}_{\epsilon,x}$  implies  $f(\rho(\cdot)) \in \mathfrak{S}_{\epsilon,x}$ . Since  $\mathcal{C}os^{-1}$  commutes with rotations,  $\mathcal{C}os^{-1}(\mathfrak{S}_{1/2,x}) \subset \mathfrak{S}_{1/4,\xi}$  yields  $\mathcal{C}os^{-1}(\mathfrak{S}_{1/2,x}) \subset \mathfrak{S}_{1/4,q}$ . Take two pairs of orthogonal vectors  $(x, q)$  and  $(q, y)$ . By Lemma 6.5, we have  $\mathcal{C}os^{-2}f(y) = 0$ . Thus,  $\mathcal{C}os^{-2}f \equiv 0$ , a contradiction.  $\square$

**Lemma 6.8.** *Let  $n \geq 3$ . Then there exists an  $\varepsilon > 0$  and an absolute constant  $c > 0$  such that for any  $x, \xi \in \mathbb{S}^{n-1}$ , there exists an even function  $f_{x,\xi}$  satisfying  $f_{x,\xi} = 0$  on  $U_\varepsilon(x)$ , and  $\mathcal{C}os^{-1}f_{x,\xi} \geq c$  on  $U_\varepsilon(\xi)$ .*

**Remark 6.2.** *If  $n$  is odd then this lemma is true by Lemma 6.2. So for the proof assume that  $n$  is even.*

*Proof.* We fix points  $x$  and  $\xi$ , and provide an  $\varepsilon > 0$ , and  $c > 0$  depending on  $x, \xi$  such that there is a function  $f_{x,\xi}$  satisfying  $f_{x,\xi} = 0$  on  $U_\varepsilon(x)$ , and  $\mathcal{C}os^{-1}f_{x,\xi} \geq c > 0$  on  $U_\varepsilon(\xi)$ . Then we use the compactness argument to prove the statement of the lemma.

Let  $\xi \notin x^\perp$ . Then there exists an  $\varepsilon > 0$ , such that  $\xi \notin E_\varepsilon(x)$ . For any function  $g$  by the even part of Theorem 5.7 the values of  $\mathcal{C}os(g)$  on  $U_\varepsilon(x)$  depend only on the values of  $g$  on  $E_\varepsilon(x)$ . Hence, we may consider an even  $C^\infty$ -function  $g$  such that  $g(\pm\xi) > 0$  and  $g(\nu) = 0$ , for  $\nu \in E_\varepsilon(x)$  and define  $f_{x,\xi} = \mathcal{C}os(g)(x)$ .

Let  $\xi \in x^\perp$ . Then Lemma 6.7 implies the existence of  $\varepsilon = \varepsilon(x, \xi) = 1/8$ , and a function  $f = f_{x,\xi}$  on  $\mathbb{S}^{n-1}$  satisfying  $f_{x,\xi} = 0$  on  $U_\varepsilon(x)$ , but  $\mathcal{C}os^{-1}f_{x,\xi}(\xi) > 0$  (change the sign of  $f_{x,\xi}$  if necessary).

Thus, we proved that for any  $x$  and  $\xi$ , there is  $\varepsilon' = \varepsilon'(x, \xi) > 0$  and there is a function  $f_{x,\xi}$  such that  $f_{x,\xi} = 0$  on  $U_{\varepsilon'}(x)$ , but  $\mathcal{C}os^{-1}f_{x,\xi}(\pm\xi) \geq c'$ ,  $c' = c'(x, \xi) > 0$ . From the continuity of the function  $\mathcal{C}os^{-1}f_{x,\xi}$  we get that  $\mathcal{C}os^{-1}f_{x,\xi} \geq c$ ,  $c = c(x, \xi) > 0$  on  $U_{\varepsilon''}(\xi)$ , for some  $\varepsilon'' > 0$ . Take  $\tilde{\varepsilon} = \tilde{\varepsilon}(x, \xi) = \min(\varepsilon', \varepsilon'')$ . We show that for any  $x$  and  $\xi$ , there is  $\tilde{\varepsilon} = \tilde{\varepsilon}(x, \xi) > 0$  and there is a function  $f_{x,\xi}$  such that  $f_{x,\xi} = 0$  on  $U_{\tilde{\varepsilon}}(x)$ , but  $\mathcal{C}os^{-1}f_{x,\xi} \geq c$  on  $U_{\tilde{\varepsilon}}(\xi)$ ,  $c = c(x, \xi) > 0$ .

Now we use the compactness argument to prove that we can choose an  $\varepsilon$  and  $c$  independent of  $x$  and  $\xi$ . We choose a finite set of  $\{x_i, \xi_i\}_{i=1}^m$  such that  $\{U_{\tilde{\varepsilon}_i/2}(x_i) \times U_{\tilde{\varepsilon}_i/2}(\xi_i)\}_{i=1}^m$  covers  $\mathbb{S}^{n-1} \times \mathbb{S}^{n-1}$ . We take

$$\varepsilon = \frac{1}{2} \min_{1 \leq i \leq m} \tilde{\varepsilon}_i \text{ and } c = \min_{1 \leq i \leq m} c(x_i, \xi_i).$$

Then for any  $(x, \xi)$  there is a  $(x_i, \xi_i)$  such that

$$U_\varepsilon(x) \times U_\varepsilon(\xi) \subset U_{\varepsilon_i}(x_i) \times U_{\varepsilon_i}(\xi_i),$$

and we may define  $f_{x,\xi} = f_{x_i,\xi_i}$ . □

**Theorem 6.3.** *Let  $n \geq 3$ . There exists a convex body  $K$  that is not a Zonoid, such that for all  $x \in \mathbb{S}^{n-1}$  there exists an  $\varepsilon(x)$  and a zonoid  $L_x$   $h_K = h_{L_x}$  on  $U_{\varepsilon(x)}(x)$ .*

*Proof.* Repeat the proof of Theorem 6.2. □

## 7. WHAT INFORMATION CAN UNIQUELY DEFINE A CONVEX BODY?

We discussed in Section 5 that a convex symmetric body can be uniquely defined from the volume of its hyperplane projections or sections. One can guess that the situation changes when we drop the symmetry assumption. Indeed, the Spherical Radon (or Cosine) transform of an odd function is zero, thus these transforms can not provide "exact" information about functions that are not even.

**Exercise 7.1.** *Construct a convex body in  $\mathbb{R}^2$  such that  $|K|\xi^\perp| = \text{const}$ , but  $K$  is not a shift or a dilate of  $B_2^2$ .*

**Exercise 7.2.** *Construct a convex body in  $\mathbb{R}^2$  such that  $|K \cap \xi^\perp| = \text{const}$ , but  $K$  is not a dilate of  $B_2^2$ .*

**Exercise 7.3.** *Generalize two previous Exercises to the case of  $\mathbb{R}^n$ . Hint: see [Ga1] for solution.*

It is a very interesting question if it is still possible to "save" the situation and find some information that would be sufficient.

**Definition 7.1.** *Consider a body  $K \subset \mathbb{R}^n$  and a direction  $u \in \mathbb{S}^{n-1}$ . We define the maximal section function  $M_K(u) : \mathbb{S}^{n-1} \rightarrow \mathbb{R}^+$ ,*

$$(34) \quad M_K(u) = \max_{t \in \mathbb{R}} |K \cap (u^\perp + tu)| = \max_{t \in \mathbb{R}} A_{K,u}(t), \quad u \in \mathbb{S}^{n-1},$$

and the projection function  $P_K : \mathbb{S}^{n-1} \rightarrow \mathbb{R}^+$ ,

$$(35) \quad P_K(u) = |K|u^\perp|, \quad u \in \mathbb{S}^{n-1}.$$

Observe that  $A_{K,u}(0) \leq M_K(u) \leq P_K(u)$ . In addition, from Brunn's Theorem (Corollary 2.1),  $M_K(u) = A_{K,u}(0)$  for symmetric, convex body  $K$ . Thus, for two symmetric convex bodies  $K_1$  and  $K_2$  such that

$$M_{K_1}(u) = M_{K_2}(u) \quad \forall u \in \mathbb{S}^{n-1},$$

and (or!)

$$P_{K_1}(u) = P_{K_2}(u) \quad \forall u \in \mathbb{S}^{n-1},$$

we get  $K_1 = K_2$ .

Below, we will address the (im)possibility of analogous results for not necessarily symmetric convex bodies.

**Exercise 7.4.** *Construct a convex body  $K \subset \mathbb{R}^2$  that is a not disc, but nevertheless satisfy  $M_K(u) = P_K(u) = 1$  for all  $u \in \mathbb{S}^1$ .*

We start with a classical affirmative result [Mart] and show that the statement in Exercise 7.4 can not be generalized to  $\mathbb{R}^3$ . We will prove that among three-dimensional convex bodies the Euclidean Ball is the only body having the same projections and maximal sections in all directions. The construction below was communicated to us by Fedor Nazarov.

**Theorem 7.1.** *Let  $K \subset \mathbb{R}^3$  be a convex body containing the origin in its interior. Assume also that the boundary  $\partial K$  is  $C^2$ -smooth with everywhere positive Gaussian curvature, and that*

$$K \cap \xi^\perp = K|\xi^\perp, \quad \forall \xi \in \mathbb{S}^2.$$

*Then  $K = B_2^3$ .*

**Corollary 7.1.** *Let  $K \subset \mathbb{R}^3$  be a convex body containing the origin in its interior and such that*

$$|K \cap \xi^\perp| = |K|\xi^\perp|, \quad \forall \xi \in \mathbb{S}^2.$$

*Then  $K = B_2^3$ .*

**Exercise 7.5.** *Prove that if all the lines containing normals to a smooth closed connected surface in  $\mathbb{R}^3$  pass through a fixed point, then the surface is a Sphere centered at this point.*

*Proof. (of Theorem 7.1).* Let  $x \in \partial K$  and let  $u$  be a normal vector to  $\partial K$  at  $x$ . Denote by  $l_x$  the line, passing through  $x$  and having the direction  $u$ . We claim at first that if  $P_{\xi^\perp}x$  is the projection of  $x$  onto the plane  $\xi^\perp$  parallel to  $l_x$ , then  $x = P_{\xi^\perp}x$ .

Indeed, since  $K \cap \xi^\perp = K|\xi^\perp$ , we have  $P_{\xi^\perp}x \in \partial K$ . By convexity, the segment  $[x, P_{\xi^\perp}x] \subset \partial K$ , which contradicts the assumption about the positivity of the Gaussian curvature (for every direction  $u \in \mathbb{S}^2$ , the set  $K \cap \{x \in \mathbb{R}^3 : x \cdot u = h_K(u)\}$  consists of one point). Thus,  $x = P_{\xi^\perp}x$ .

Now let  $x, y \in \partial K$  be two points on the boundary with non-parallel normal vectors, and let  $l_x$  and  $l_y$  be two lines constructed as above. Then,  $l_x$  and  $l_y$  intersect. Indeed, let  $\xi^\perp$  be the plane parallel to  $l_x$  and  $l_y$ . Repeating the above reasonings, we have  $x = P_{\xi^\perp}x$  and  $y = P_{\xi^\perp}y$ . Hence,  $l_x$  and  $l_y$  belong to the same plane and intersect each other.

Finally, observe that in  $\mathbb{R}^3$  (this is a crucial step that distinguishes  $\mathbb{R}^3$  from  $\mathbb{R}^2$ ) the following is true: if we have a collection of lines (in almost every direction), such that any pair of them intersect, then they all intersect in one point.

Thus, all lines  $l_x$  intersect in one point. We finish the proof applying Exercise 7.5.  $\square$

**Exercise 7.6.** *Observe that if  $K \cap \xi^\perp = K|\xi^\perp$ , then  $K \cap \xi^\perp$  is maximal in area among all sections of  $K$  orthogonal to  $\xi$ .*

- *Is it possible to get rid of the smoothness and curvature assumptions in the above theorem?*
- *Is it possible just to assume that  $P_K = M_K$ ? In this connection see also Theorem 3.4.6 from [Th], page 89.*
- *Is it possible to prove the analogue of this result in higher dimensions?*
- *Let  $\xi \in \mathbb{S}^{n-1}$ . A subset  $A_\xi$  of  $\partial K$  is called the "shadow boundary" of  $K$  in the direction  $\xi$ , if  $A_\xi|\xi^\perp = \partial(K|\xi^\perp)$ . Prove that if the shadow boundary of  $K$  is flat in every direction, then  $K$  is an ellipsoid. **Hint:** see [Th], page 91.*

- If all maximal sections of convex body intersect at one point then the body is symmetric with respect to this point. **Hint:** see [MMO], [RY].
- Conclude that if all maximal sections of a body  $K$  are of the same volume and intersect at one point, then the body is an Euclidean Ball.

**7.1. Questions of Bonnesen and Klee.** In 1929 T. Bonnesen asked whether every convex body  $K \subset \mathbb{R}^3$  is uniquely defined by  $P_K$  and  $M_K$ , (see [BF], page 51).

**Open Problem 7.1.** Let  $n \geq 3$ . Are the conditions  $M_K \equiv c_1$ ,  $P_K \equiv c_2$  compatible for  $c_1 < c_2$ , or not?

In 1969 V. Klee asked whether the condition  $M_{K_1} \equiv M_{K_2}$  implies  $K_1 = K_2$ , or, at least, whether the condition  $M_K \equiv c$  implies that  $K$  is a Euclidean ball, [K11], [K12].

Two bodies of revolution  $K_1, K_2$  such that  $K_1$  is origin-symmetric,  $K_2$  is not origin-symmetric, but  $M_{K_1} \equiv M_{K_2}$ , were recently constructed (see [GRYZ]). This answers the first question of V. Klee.

**Exercise 7.7.** Answer the first question of V. Klee by performing the following steps.

- Define  $K_2$  using its radial function as a small perturbation of the Euclidean ball,  $\rho_{K_2}(x) = (|x|^3 + \epsilon x_n^3)^{-1/3}$ ,  $x \in \mathbb{R}^n$ , where  $\epsilon > 0$  is very small.
- Show that  $K_2$  is not symmetric.
- Show that  $M_{K_2}$  is an infinitely smooth function on  $\mathbb{S}^{n-1}$  (this is the hardest technical point of the construction). **Hint:** see Lemma 3.4, [GRYZ].
- Define the second body  $K_1$  as  $\rho_{K_1}(u) := ((n-1)\mathcal{R}^{-1}M_{K_2}(u))^{1/(n-1)}$ ,  $u \in \mathbb{S}^{n-1}$ .
- Show that  $K_1$  is origin-symmetric and convex (we are not far from the Euclidean ball) and conclude that the maximal (in volume) sections of  $K_1$  are the central ones.
- Conclude that  $\forall u \in \mathbb{S}^{n-1}$  we have

$$M_{K_1}(u) = |K_1 \cap u^\perp| = \frac{1}{n-1} \mathcal{R} \rho_{K_1}^{n-1}(u) = \mathcal{R}(\mathcal{R}^{-1}M_{K_2})(u) = M_{K_2}(u).$$

In 2011 the following two results were presented, [NRZ2], [NRZ3]:

**Theorem 7.2.** If  $n \geq 3$ , there exists a convex body of revolution  $K \subset \mathbb{R}^n$  satisfying  $M_K \equiv \text{const}$ , that is not a Euclidean ball.

**Theorem 7.3.** If  $n \geq 4$  is even, there exist two essentially different convex bodies of revolution  $K_1, K_2 \subset \mathbb{R}^n$  such that  $A_{K_1, \cdot}(0) \equiv A_{K_2, \cdot}(0)$ ,  $M_{K_1} \equiv M_{K_2}$ , and  $P_{K_1} \equiv P_{K_2}$ .

Theorem 7.2 answers the second question of Klee, and Theorem 7.3 answers the analogue of the question of Bonnesen in even dimensions. The proofs of the above theorems are quite involved! But a special case of  $\mathbb{R}^4$  shows the general idea of the construction and is much (technically) simpler, [NRZ2]. We will present it below.

As in many places in these notes, we are again going to reduce the geometric question to a question in analysis. We will translate the problem into a language of integral equations. From now on, we assume that  $n \geq 3$ . We will be dealing with the bodies of revolution

$$K_f = \{x \in \mathbb{R}^n : x_2^2 + x_3^2 + \dots + x_n^2 \leq f^2(x_1)\},$$

obtained by the rotation of a smooth concave function  $f$  supported on  $[-1, 1]$  about the  $x_1$ -axis.

Note that  $K$  is rotation invariant, thus every its hyperplane section is equivalent to a section by a hyperplane with normal vector in the  $(x_1, x_2)$ -plane.

Before we proceed with the next statement we recommend the following example suggested by Alexey Goncharov.

**Exercise 7.8.** *Let  $K \subset \mathbb{R}^3$  be a convex body of revolution which is a union of two half-ellipsoids of revolution,*

$$K_a = \{(x_1, x_2, x_3) \in \mathbb{R}^3 : \frac{x_1^2}{a^2} + x_2^2 + x_3^2 \leq 1, x_1 \geq 0\},$$

$$K_b = \{(x_1, x_2, x_3) \in \mathbb{R}^3 : \frac{x_1^2}{b^2} + x_2^2 + x_3^2 \leq 1, x_1 \leq 0\},$$

where  $a + b = 2$ . Prove that

$$\begin{aligned} |K \cap (\xi^\perp + t\xi)| &= \frac{a(\cos^2 \alpha + a^2 \sin^2 \alpha - t^2)}{(\cos^2 \alpha + a^2 \sin^2 \alpha)^{3/2}} \left( \frac{\pi}{2} + \arcsin \frac{ta \sin \alpha}{\cos \alpha \sqrt{\cos^2 \alpha + a^2 \sin^2 \alpha - t^2}} \right) \\ &\quad - \frac{b(\cos^2 \alpha + b^2 \sin^2 \alpha - t^2)}{(\cos^2 \alpha + b^2 \sin^2 \alpha)^{3/2}} \left( -\frac{\pi}{2} + \arcsin \frac{tb \sin \alpha}{\cos \alpha \sqrt{\cos^2 \alpha + b^2 \sin^2 \alpha - t^2}} \right) \\ &\quad + \frac{t \sin \alpha \sqrt{a^2 \cos^2 \alpha - t^2 a^2}}{\cos^2 \alpha (\cos^2 \alpha + a^2 \sin^2 \alpha)} - \frac{t \sin \alpha \sqrt{b^2 \cos^2 \alpha - t^2 b^2}}{\cos^2 \alpha (\cos^2 \alpha + b^2 \sin^2 \alpha)}, \end{aligned}$$

where  $\xi = (\sin \alpha, \cos \alpha, 0)$ . Is it possible to prove or disprove **directly** that the maximal sections in every direction are of the same area?

The above exercise shows how hard it is to compute the maximal sections even in the "simplest" case. The lemmata below shows how to avoid those computations.

**Lemma 7.1.** *Let  $L(\xi) = L(s, h, \xi) = s\xi + h$  be the linear function with slope  $s$ , and let  $H(L) = \{x \in \mathbb{R}^n : x_2 = L(x_1)\}$  be the corresponding hyperplane. Then the corresponding section  $K \cap H(L)$  is of maximal volume iff*

$$(36) \quad \int_{-x}^y (f^2 - L^2)^{(n-4)/2} L = 0,$$

where  $-x$  and  $y$  are the first coordinates of the points at which  $L$  intersects the graphs of  $-f$  and  $f$ , respectively (see Figure 10).

*Proof.* Fix  $s > 0$ . Observe that the slice  $K \cap H(L) \cap H_\xi$  of  $K \cap H(L)$  by the hyperplane  $H_\xi = \{x \in \mathbb{R}^n : x_1 = \xi\}$ ,  $-1 < \xi < 1$ , is the  $(n-2)$ -dimensional Euclidean ball  $\{(x_3, x_4, \dots, x_n) : x_3^2 + \dots + x_n^2 \leq r^2\}$  of radius  $r = \sqrt{f^2(\xi) - L^2(\xi)}$ . Hence,

$$(37) \quad |K \cap H(L)| = |B_2^{n-2}| \sqrt{1+s^2} \int_{-x(s)}^{y(s)} (f^2(\xi) - L^2(\xi))^{(n-2)/2} d\xi.$$

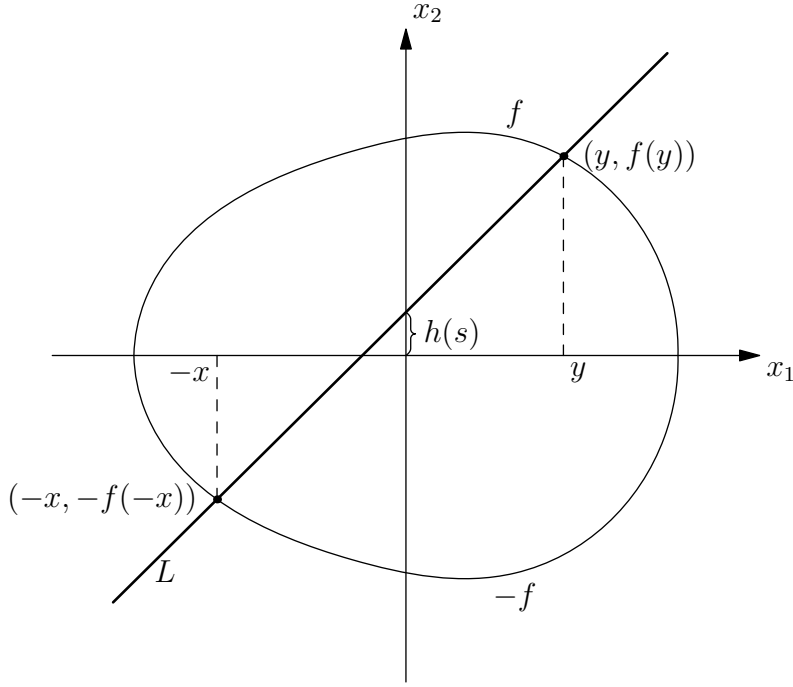

FIGURE 10. View of  $K$  and  $H(L)$  in  $(x_1, x_2)$ -plane.

The section  $K \cap H(L)$  is of maximal volume iff

$$\frac{d}{dh}|K \cap H(L)| = 0,$$

where in the *only if* part we use Brunn's Theorem (Corollary 2.1). Computing the derivative, we conclude that for a given  $s \in \mathbb{R}$ , the section  $K \cap H(L)$  is of maximal volume iff (36) holds.  $\square$

**Lemma 7.2.** *Let  $L(s, \xi) = s\xi + h(s)$  be a family of linear functions parameterized by the slope  $s$ . For each  $L$  in our family, define the hyperplane  $H(L)$  by  $H(L) = \{x \in \mathbb{R}^n : x_2 = L(x_1)\}$ , (see Figure 10). The corresponding family of sections is of constant volume  $|B_2^{n-1}|$  iff*

$$(38) \quad \int_{-x}^y (f^2 - L^2)^{(n-2)/2} = \frac{\text{const}}{\sqrt{1+s^2}}, \quad \text{for all } s > 0.$$

*Proof.* The right hand side in (37) is constant iff (38) holds.  $\square$

Now we observe that the system of equations (36), (38) is considerably simplified when  $n = 4$ . In this case we will show that the *maximal sections correspond to level intervals*, see Proposition 7.1 below. We will also prove that *the values of the maximal section function  $M_K$  depend on the distribution function  $t \rightarrow |\{f > t\}|$  only.*

The **idea** in the case  $n = 4$  is the following. In order to satisfy (36) (i.e., the condition that the integral of the linear function  $L$  is zero), the corresponding line

segment connecting the points  $(-x, f(-x))$  and  $(y, f(y))$  must intersect the  $x_1$ -axis in the middle. Hence, the shaded triangles are similar (see Figure 11) and  $-f(-x) = f(y)$ .

More precisely, we have

**Theorem 7.4.** *Let  $n = 4$ ,  $K_f = \{x \in \mathbb{R}^4 : x_2^2 + x_3^2 + x_4^2 \leq f^2(x_1)\}$ , and let*

$$u = u(s) = \left(-\frac{s}{\sqrt{1+s^2}}, \frac{1}{\sqrt{1+s^2}}, 0, 0\right) \in \mathbb{S}^3, \quad s > 0.$$

Then,

$$(39) \quad M_{K_f}(u) = \pi\sqrt{1+s^2} \left( \frac{2}{3} t^2 |\{f > t\}| + \int_t^\infty 2\tau |\{f > \tau\}| d\tau \right),$$

where  $t$  is the unique solution of the equation  $s = 2t/|\{f > t\}|$ .

In particular, if  $f_1$  and  $f_2$  are equi-measurable (i.e., for every  $\tau > 0$ , we have  $|\{f_1 > \tau\}| = |\{f_2 > \tau\}|$ ), then  $M_{K_{f_1}} \equiv M_{K_{f_2}}$ .

Theorem 7.4 is a simple consequence of the following two propositions.

**Proposition 7.1.** *Let  $f, s, u(s)$  be as in Theorem 7.4. Then the section of maximal volume in the direction  $u(s)$  is the one that corresponds to the line joining  $(-x, -t)$  and  $(y, t)$ , where  $t$  is such that  $s = 2t/|\{f > t\}|$ ,  $0 < t < \max_{\xi \in [-1,1]} f(\xi)$ , (see Figure 11).*

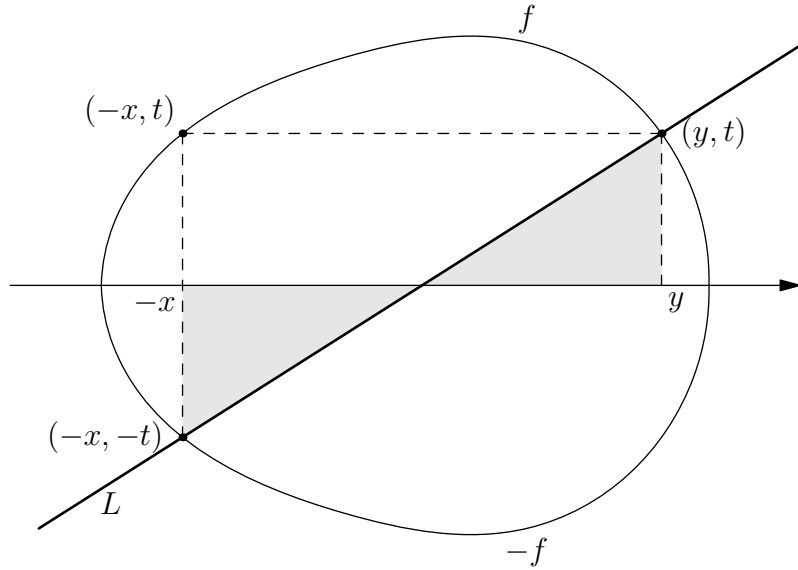

FIGURE 11. Maximal slice in  $\mathbb{R}^4$

*Proof.* Fix  $s > 0$ . Since the distribution function is decreasing to 0, there exists a unique  $t$  satisfying  $s = 2t/|\{f > t\}|$ . To prove that

$$\int_{-x}^y L(\xi) d\xi = 0$$

observe that two shaded triangles are congruent, (see Figure 11). □

**Proposition 7.2.** *Let  $K, f, t, x, y$  be as in the previous proposition, and let the line  $L$  be passing through the points  $(-x, -t), (y, t)$ . Then (39) holds.*

*Proof.* Note that

$$\int_{-x}^y L^2 = (x+y) \frac{t^2}{3} = \frac{t^2}{3} |\{f > t\}|,$$

and

$$\int_{-x}^y f^2 = \int_{\{f>t\}} f^2 = t^2 |\{f > t\}| + \int_t^\infty 2\tau |\{f > \tau\}| d\tau.$$

□

**Proof of Theorem 7.2.** Let  $f_o(\xi) = \sqrt{1 - \xi^2}$ ,  $\xi \in [-1, 1]$ . Take a concave function  $f$  on  $[-1, 1]$  such that  $f \neq f_o$  and  $f$  is equimeasurable with  $f_o$ .

**Exercise 7.9.** *Adjust the Exercise 7.8 to  $\mathbb{R}^4$ .*

- *Compute the slicing function of  $K$ . Is it possible to see the result of Theorem 7.2 directly?*
- *Now take a different road. Compute a function  $f$  such that  $K = K_f$ .*
- *Prove that  $f$  is equimeasurable with  $f_o$ .*

**Proof of Theorem 7.3.** Let  $\varphi$  and  $\psi$  be two smooth functions supported by the intervals  $D = [\frac{1}{2} - \delta, \frac{1}{2} + \delta]$  and  $E = [1 - \delta, 1]$  respectively, where  $0 < \delta < \frac{1}{4}$ . Define

$$f_+(\xi) = f_o(\xi) + \varepsilon\varphi(\xi) + \varepsilon\psi(\xi),$$

and

$$f_-(\xi) = f_o(\xi) + \varepsilon\varphi(-\xi) + \varepsilon\psi(\xi),$$

where  $\varepsilon > 0$  is so small that  $f_\pm$  are concave on  $[-1, 1]$ , (see Figure 12).

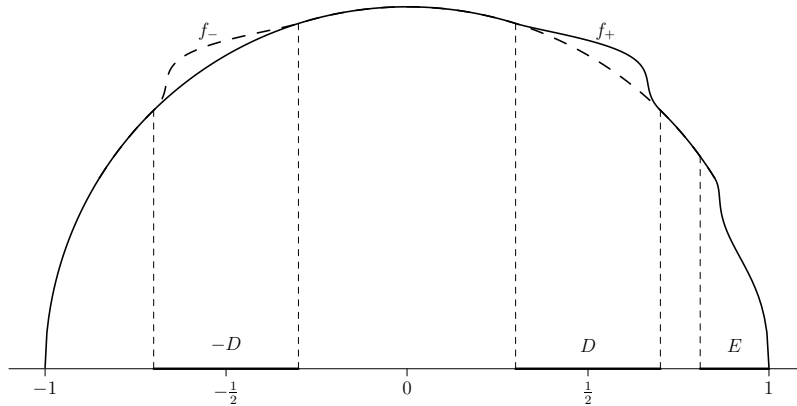

FIGURE 12. Graph of functions  $f_\pm$

Define  $K_1 = K_{f_+}$  and  $K_2 = K_{f_-}$ .

Observe that  $f_+(\xi) = f_-(\xi) \forall \xi \in [-1, 1] \setminus (D \cup (-D))$ , and  $f_+(\xi) = f_-(\xi) \forall \xi \in D \cup (-D)$ . Hence,  $f_+$  and  $f_-$  are equi-measurable. By Proposition 7.1 we have  $M_{K_1} \equiv M_{K_2}$ .

Observe that we have  $h_{K_1}(u) = h_{K_2}(u)$  and  $\rho_{K_1}(u) = \rho_{K_2}(u)$  for all directions  $u = (\xi, \sqrt{1-\xi^2}, 0, 0) \in \mathbb{S}^3$ ,  $\xi \in [0, 1] \setminus D$ . Observe also that  $h_{K_1}(u) = h_{K_2}(-u)$  and  $\rho_{K_1}(u) = \rho_{K_2}(-u)$  for all directions  $u = (\xi, \sqrt{1-\xi^2}, 0, 0) \in \mathbb{S}^3$ ,  $\xi \in D$ . Hence, the non-ordered pairs

$$\{h_{K_1}(u), h_{K_1}(-u)\}, \{h_{K_2}(u), h_{K_2}(-u)\}$$

coincide for all  $u \in \mathbb{S}^3$ , and so do the pairs

$$\{\rho_{K_1}(u), \rho_{K_1}(-u)\}, \{\rho_{K_2}(u), \rho_{K_2}(-u)\}.$$

By the result of Goodey, Schneider and Weil, we have  $P_{K_1} \equiv P_{K_2}$ , [GSW]. Also,

$$A_{K_1, \theta}(0) = \frac{1}{3} \int_{\mathbb{S}^3 \cap \theta^\perp} \frac{\rho_{K_1}^3(-u) + \rho_{K_1}^3(u)}{2} du = \frac{1}{3} \int_{\mathbb{S}^3 \cap \theta^\perp} \frac{\rho_{K_2}^3(-u) + \rho_{K_2}^3(u)}{2} du = A_{K_2, \theta}(0)$$

for all  $\theta \in \mathbb{S}^3$ .

## 8. ISOMORPHIC VERSION OF THE MAHLER CONJECTURE

**8.1. Introduction.** In this section we will discuss the strongest result related to the Mahler conjecture: the Bourgain-Milman inequality. We first notice that by the result of F. John (Theorem 2.1) we get that for any convex symmetric  $K \subset \mathbb{R}^n$ , there exists a  $T \in GL(n)$  such that  $B_2^n \subset TK \subset \sqrt{n}B_2^n$  and thus  $\frac{1}{\sqrt{n}}B_2^n \subset (TK)^\circ \subset B_2^n$ , which gives

$$\mathcal{P}(K) \geq \frac{1}{n^{n/2}} \mathcal{P}(B_2^n) \geq \frac{1}{n^{n/2}} \mathcal{P}(B_\infty^n).$$

**Exercise 8.1.** Show that there is an absolute constant  $c > 0$  such that

$$\mathcal{P}(B_2^n) \geq \mathcal{P}(B_\infty^n) \geq c^n \mathcal{P}(B_2^n).$$

**Theorem 8.1.** (*Bourgain-Milman inequality*) There exists an absolute constant  $c > 0$  such that for all convex symmetric  $K \subset \mathbb{R}^n$ :

$$(40) \quad \mathcal{P}(K) \geq c^n \mathcal{P}(B_\infty^n).$$

The original proof can be found in [BM], (see also [Pi], p.100) for more detailed version. Kuperberg [Ku] gave a new proof of this result with a better constant  $c = \pi/4$ , yet another proof (without computation of constant  $c$ ) was recently presented by Giannopoulos, Paouris, and Vritsiou [GPV].

We will present here the Fourier Analytic proof due to Nazarov [Naz] (the proof gives a slightly worse constant  $c = (\pi/4)^3$ ). The proof is another example of the interplay between convex geometry and the Fourier analysis.

Before giving the proof let us explain why the improvement from  $(1/\sqrt{n})^n$  to  $c^n$  is the best possible step one can make, before actually proving (or disproving) the Mahler conjecture.

Indeed, assume we can achieve an asymptotic behavior better than  $c^n$ ,  $0 < c < 1$ , i.e. we have (40) with  $\gamma(n)$  instead of  $c^n$ , and  $\lim_{n \rightarrow \infty} \gamma(n)/c^n = \infty$ , (say,  $\gamma(n) = c_1^{\sqrt{n}}$  for some

$0 < c_1 < 1$ ), but there is a dimension, say  $l$ , such that the Mahler conjecture is false in  $\mathbb{R}^l$ . Then, there exists a convex symmetric body  $K \subset \mathbb{R}^l$  such that  $\mathcal{P}(K) < \mathcal{P}(B_\infty^l)$  or

$$\mathcal{P}(K) \leq c_2 \mathcal{P}(B_\infty^l), \text{ for some } 0 < c_2 < 1.$$

Taking  $K'$  to be the  $m$ th direct sum of copies of  $K$ ,  $K' = K \oplus \cdots \oplus K \subset \mathbb{R}^n$ ,  $n = ml$ , and iterating Lemma 3.2 we use the Bourgain-Milman inequality to get

$$(41) \quad \gamma(lm) \mathcal{P}(B_\infty^{lm}) \leq \mathcal{P}(K') = \mathcal{P}(K \oplus \cdots \oplus K) \leq c_2^m \mathcal{P}(B_\infty^{lm}) = (c_2^{1/l})^{lm} \mathcal{P}(B_\infty^{lm}).$$

This yields  $\gamma(n) \leq c^n$  for  $n = ml$  and  $c = c_2^{1/l}$ , and we get a contradiction with  $\lim_{n \rightarrow \infty} \gamma(n)/c^n = \infty$ , provided  $m$  is big enough.

Now let us get back to Nazarov's construction. To distinguish between  $n$ -dimensional volume in  $\mathbb{R}^n$  and  $2n$ -dimensional volume in  $\mathbb{C}^n$  we will denote the first by  $v_n$  and the second by  $v_{2n}$ .

The proof is divided into several parts. Here is a short plan (all definitions and details will be provided below).

**Part I.** *Main Idea: the application of the Paley-Wiener Theorem.*

**Part II.** *The adjustment of the main idea to the context of Bergman spaces  $A^2(T_K)$ , where  $T_K$  is a tube domain,*

$$T_K = \{z \in \mathbb{C}^n : z = x + iy, x \in \mathbb{R}^n, y \in K\},$$

and the reduction of the proof to the lower estimate on the Bergman kernel  $\mathcal{K}_{T_K}(0, 0)$ . More precisely, the functional

$$(42) \quad \mathbb{F}_{PW} : K \rightarrow v_n(K)v_n(K^\circ) = \mathcal{P}(K)$$

that "goes along" with the Paley-Wiener space, is replaced by the "Bergman Space functional"

$$(43) \quad \mathbb{F}_B : K \rightarrow v_{2n}(K_{\mathbb{C}})\mathcal{K}_{T_K}(0, 0).$$

Here

$$K_{\mathbb{C}} = \{z \in \mathbb{C}^n : |z \cdot t| \leq 1 \text{ for all } t \in K^\circ\} \subset K \times K, \quad v_n(K) = 1,$$

and the last inclusion is the inclusion of subsets in  $\mathbb{R}^{2n}$ .

**Part III.** *A certain auxiliary construction that includes a pluri-sub-harmonic function  $\phi$  defined on  $T_K$ , and a Mexican-hat function  $C^\infty$ -function  $g$  supported on  $K_{\mathbb{C}}$ .*

**Part IV.** *The final part of the proof.* We apply the Theorem of Hörmander to the construction of the analytic function  $F = F(\phi, g) \in A^2(T_K)$ , satisfying  $F(0) = 1$ , and connecting the quantities  $\mathcal{K}_{T_K}(0, 0)$ ,  $v_{2n}(K_{\mathbb{C}})$  with  $v_n(K^\circ)$ . We prove

$$(44) \quad v_n(K^\circ) \geq \frac{(2\pi)^n}{2^n n!} v_{2n}(K_{\mathbb{C}})\mathcal{K}_{T_K}(0, 0),$$

together with the sharp lower estimate for  $v_{2n}(K_{\mathbb{C}})\mathcal{K}_{T_K}(0, 0)$ :

$$(45) \quad v_{2n}(K_{\mathbb{C}})\mathcal{K}_{T_K}(0, 0) \geq \left(\frac{\pi^2}{16}\right)^n,$$

which yields the final estimate

$$(46) \quad v_n(K^\circ) \geq \left(\frac{\pi}{4}\right)^{3n} \frac{4^n}{n!}.$$

We will elaborate on each part step by step. Since we are going to use many facts related to the Paley-Wiener Theorem, the Bergman Spaces, and the Hörmander theorem, we decided to collect the necessary background material separately in Appendices A, B and C. We strongly recommend the reader to look at Appendices before he/she starts reading Nazarov's proof. For convenience many parts of the proof are split into Exercises.

## 9. PART I. MAIN IDEA: THE APPLICATION OF THE PALEY-WIENER THEOREM

**Heuristics.** The Paley-Wiener Theorem tells us that the Fourier Transform of the characteristic function of the convex body, is the characteristic function of its polar, see Appendix A.

If  $f \in \text{PW}(K)$  is the Fourier transform of  $g$ , then, by Plancherel's formula,  $\|f\|_{L^2(\mathbb{R}^n)}^2 = (2\pi)^n \|g\|_{L^2(K^\circ)}^2$ . By the Cauchy-Schwarz inequality, we have

$$|f(0)|^2 = \left| \int_{K^\circ} g \, dv_n \right|^2 \leq v_n(K^\circ) \|g\|_{L^2(K^\circ)}^2 = \frac{1}{(2\pi)^n} v_n(K^\circ) \|f\|_{L^2(\mathbb{R}^n)}^2$$

and that the equality sign is attained when  $g = 1$  in  $K^\circ$ . Thus,

$$(47) \quad v_n(K^\circ) = (2\pi)^n \sup_{f \in \text{PW}(K)} |f(0)|^2 \cdot \|f\|_{L^2(\mathbb{R}^n)}^{-2}.$$

**Remark 9.1.** Let  $v_n(K) = 1$ . Note that the quantity on the right does not include  $K^\circ$  formally, so the problem of proving a lower bound for  $v_n(K^\circ)$  has been thus transformed into the problem of finding an example of an entire function  $f \in \text{PW}(K)$  that has not too small value at the origin and not too large  $L^2(\mathbb{R}^n)$ -norm.

**Exercise 9.1.** Let  $n = 1$ ,  $K = (-1/2, 1/2)$ . Then  $K^\circ = (-2, 2)$ . Prove that for the analytic function

$$f(z) = \int_{\mathbb{R}} 1_{K^\circ}(t) e^{-z \cdot t} \, dv_1(t),$$

we have equality in (47). Prove the analogous result for the cube  $(-2, 2)^n$ . **Hint:** Check that  $f(0) = 4$ , and use  $\int_0^\infty \frac{\sin^2 t}{t^2} dt = \frac{\pi}{2}$ .

**Open Problem 9.1.** Find the analytic function that does the job for  $n \geq 2$ .

**Remark 9.2.** The construction of fast decaying on  $\mathbb{R}^n$  analytic functions of several complex variables is quite a non-trivial task by itself, and we do not know how to do it in the context of the Paley-Wiener space. The remarkable theorem of Hörmander allows, however, as Fedor Nazarov puts it, "to conjure up" such functions in Bergman type spaces  $L^2(T_K, e^{-\phi} dv_{2n})$  with a suitable pluri-sub-harmonic  $\phi$ .

**Remark 9.3.** In the remaining part of the proof we will try to trade the quantity in (51) for

$$\sqrt{\int_{T_K} |f(z)|^2 e^{-\phi(z)} dv_{2n}(z)}.$$

Here  $T_K$  is a tube domain,  $\phi(z)$  is a pluri-sub-harmonic function we are going to construct, and  $f$  is an analytic function from the Bergman space (see Appendix B). As a result, we will substitute  $\mathcal{P}(K)$  with  $v_{2n}(K_{\mathbb{C}})\mathcal{K}_{T_K}(0,0)$ , where  $\mathcal{K}_{T_K}$  is the Bergman kernel. We loose the precision in the final estimate when we pass from the Paley-Wiener space to the Bergman Space.

## 10. PART II. THE ADJUSTMENT OF THE MAIN IDEA TO THE CONTEXT OF THE BERGMAN SPACE $A^2(T_K)$

Let  $K$  be any *strictly convex open* subset of  $\mathbb{R}^n$  and let  $A^2(T_K)$  be the Bergman space (see Appendix B) in the tube domain  $T_K = \{x + iy : x \in \mathbb{R}^n, y \in K\} \subset \mathbb{C}^n$ .

### 10.1. The Rothaus-Korányi-Hsin formula for the reproducing kernel in a tube domain $T_K$ .

The next theorem is due to Hsin, [Hs] (see also [R] and [Ko]).

**Theorem 10.1.** *The reproducing kernel  $\mathcal{K}(z, w) = \mathcal{K}_{T_K}(z, w)$  associated with the Hilbert space  $A^2(T_K)$ :*

$$\mathcal{K}(z, w) = \frac{1}{(2\pi)^n} \int_{\mathbb{R}^n} \frac{e^{i(z-\bar{w})\cdot t}}{J_K(t)} dv_n(t)$$

where

$$J_K(t) = \int_K e^{-2x\cdot t} dv_n(x).$$

### 10.2. Estimates related to the Bergman Kernel in the tube domain.

**Exercise 10.1.** *Use the above theorem to prove that if  $0 \in K$ , then*

$$\mathcal{K}(0,0) = \frac{1}{(2\pi)^n} \int_{\mathbb{R}^n} \frac{dv_n(t)}{J_K(t)}.$$

**Exercise 10.2.** *Prove that*

$$J_K(t) \geq 2^{-n} v_n(K) e^{-\|t\|_{K^\circ}}.$$

**Hint:** Since  $(x+y)/2 \in K$  for all  $x, y \in K$ , and since the function  $x \mapsto e^{-x\cdot t}$  is convex, one can write

$$J_K(t) \geq 2^{-n} \int_K e^{-x\cdot t - y\cdot t} dv_n(x) \geq 2^{-n} v_n(K) e^{-y\cdot t}$$

for all  $y \in K$ . Maximize this quantity over  $y$ .

**Exercise 10.3.** *Prove that*

$$\int_{\mathbb{R}^n} \frac{dv_n(t)}{J_K(t)} \leq 2^n v_n(K)^{-1} \int_{\mathbb{R}^n} e^{-\|t\|_{K^\circ}} dv_n(t) = 2^n n! v_n(K^\circ) v_n(K)^{-1}.$$

Conclude that

$$v_n(K^\circ) \geq \frac{(2\pi)^n}{2^n n!} \mathcal{K}(0,0),$$

provided  $v_n(K) = 1$ .

**Hint:** For the computation of the last integral see the proof of Lemma 3.2.

**Remark 10.1.** Let  $v_n(K) = 1$ . Our goal is to estimate  $\mathcal{K}_{T_K}(0, 0)$  from below. We remark that the part of the imprecision in the final constant in (46) has already come from the estimate in Exercise 10.3.

**Exercise 10.4.** Show that for all  $F \in A^2(T_K)$ , we have

$$|F(0)|^2 \leq \mathcal{K}(0, 0) \|F\|_{A^2(T_K)}^2.$$

Conclude that

$$\mathcal{K}(0, 0) = \sup_{F \in A^2(T_K)} \frac{|F(0)|^2}{\|F\|_{A^2(T_K)}^2},$$

(cf. (47)).

**Hint:** Use property c) of Theorem B.2 *twice* together with b) and the Cauchy-Schwarz inequality. Take  $F(\zeta) = \overline{\mathcal{K}(0, \zeta)}$  to make a conclusion.

**Remark 10.2.** Let  $v_n(K) = 1$ . In the last section we will construct an analytic function  $F \in A^2(T_K)$ , satisfying  $F(0) = 1$  that will help us to get the following lower bound on  $\mathcal{K}(0, 0)$  :

$$\mathcal{K}(0, 0) \geq \frac{1}{(2\pi)^n} \left(\frac{\pi^3}{8}\right)^n \frac{1}{v_{2n}(K_{\mathbb{C}})},$$

where

$$K_{\mathbb{C}} = \{z \in \mathbb{C}^n : |z \cdot t| \leq 1 \text{ for all } t \in K^\circ\} \subset K \times K.$$

Observe that the estimate could be written in the form

$$(48) \quad v_{2n}(K_{\mathbb{C}}) \int_{\mathbb{R}^n} \frac{dv_n(t)}{J_K(t)} \geq \left(\frac{\pi^3}{8}\right)^n.$$

Combining the last estimate with the one in Exercise 10.3, and noting that  $v_{2n}(K_{\mathbb{C}}) \leq 1$ , we obtain (46).

**Exercise 10.5.** Observe that the functional

$$K \quad \rightarrow \quad v_{2n}(K_{\mathbb{C}}) \int_{\mathbb{R}^n} \frac{dv_n(t)}{J_K(t)}$$

has a multiplicative structure. Namely, prove that for  $K' = K \oplus K \oplus \dots \oplus K$  which is a direct sum of  $m$  convex bodies  $K$  in  $\mathbb{R}^n$ , we have

$$K'_{\mathbb{C}} = K_{\mathbb{C}} \oplus K_{\mathbb{C}} \oplus \dots \oplus K_{\mathbb{C}},$$

and

$$J_{K'}(t_1, \dots, t_m) = J_K(t_1) \cdot \dots \cdot J_K(t_m).$$

Conclude that

$$v_{2mn}(K'_{\mathbb{C}}) \int_{\mathbb{R}^{mn}} \frac{dv_{mn}(t_1, \dots, t_m)}{J_K(t_1, \dots, t_m)} = \left( v_{2n}(K_{\mathbb{C}}) \int_{\mathbb{R}^n} \frac{dv_n(t)}{J_K(t)} \right)^m.$$

Thus, by Exercise 10.4, we have to construct a function  $F \in A^2(T_K)$  with  $|F(0)|$  not too small compared to  $\|F\|_{A^2(T_K)}$ . For this construction, we shall need the celebrated Hörmander theorem, see Appendix C.

The reader is advised to finish this section by solving two Exercises, showing that estimate (48) is exact.

**Exercise 10.6.** Let  $n = 1$  and let  $K = (-1/2, 1/2)$ . Prove that  $v_2(K_{\mathbb{C}}) = \pi/4$ , and

$$J_K(t) = \frac{e^t - e^{-t}}{2t}, \quad \int_{\mathbb{R}} \frac{dt}{J_K(t)} = \frac{\pi^2}{2}.$$

Conclude that for the interval in  $\mathbb{R}$ , (and, thereby, for the cube in every dimension), the equality sign in (48) is attained.

**Hint:** Check that

$$\begin{aligned} \int_{\mathbb{R}} \frac{dt}{J_K(t)} &= 4 \int_0^{\infty} \frac{t}{e^t - e^{-t}} = 4 \int_0^{\infty} t \left( \sum_{k \geq 1, k \text{ odd}} e^{-kt} \right) dt \\ &= 4 \sum_{k \geq 1, k \text{ odd}} \int_0^{\infty} t e^{-kt} dt = 4 \sum_{k \geq 1, k \text{ odd}} \frac{1}{k^2} = \frac{\pi^2}{2}. \end{aligned}$$

## 11. PART III. THE AUXILIARY CONSTRUCTION

Let  $K \subset \mathbb{R}^n$  be such that  $v_n(K) = 1$ . We are going to apply the Hörmander Theorem (see Appendix C) to construct a certain analytic function  $F$  in the *tube domain*  $T_K$ , that will help us to obtain (48). The construction of  $F$  will depend on two auxiliary functions  $\phi$  and  $g$ , where  $\phi$  is a *pluri-sub-harmonic* function defined on  $T_K$ , and  $g$  is a *Mexican-hat* function supported on  $K_{\mathbb{C}}$ .

**11.1. The construction of the the pluri-sub-harmonic  $\phi$  on the tube domain  $T_K$ .**

**Exercise 11.1.** Prove that a tube domain  $T_K \subset \mathbb{C}^n$  is pseudo-convex, provided  $K$  is a convex domain in  $\mathbb{R}^n$ ; it is strictly pseudo-convex, provided  $K$  is strictly convex.

**Hint:**  $T_K$  is convex iff  $K$  is convex. See Section 3.5.2, page 160, in [Kr] in this connection.

**Exercise 11.2.** Let  $K$  be an origin-symmetric convex body. Prove that for every  $t \in K^{\circ}$ , the mapping  $z \rightarrow z \cdot t$  sends  $T_K$  to the horizontal strip  $|\operatorname{Im} \zeta| < 1$ .

Let

$$\Phi(\zeta) = \frac{4 e^{\frac{\pi}{2}\zeta} - 1}{\pi e^{\frac{\pi}{2}\zeta} + 1}$$

be the standard conformal mapping of  $|\operatorname{Im} \zeta| < 1$  to the disc of radius  $4/\pi$  centered at the origin.

**Exercise 11.3.** Observe that  $\Phi(0) = 0$  and  $\Phi'(0) = 1$ . Show that

$$|\log |\Phi(\zeta) - \log |\zeta|| \leq C |\zeta|, \quad \text{for } |\zeta| \leq \frac{1}{2} \quad \text{with some } C \geq 1.$$

**Exercise 11.4.** Define

$$\phi(z) = R^{-2}|y|^2 + 2n \log \sup_{t \in K^\circ} |\Phi(z \cdot t)|, \quad z = x + iy \in \mathbb{C}^n,$$

where  $R$  is a positive fixed constant. Prove that  $\phi$  is pluri-sub-harmonic and satisfies the conditions of the Hörmander existence theorem with  $\tau = R^{-2}/4$ .

**Hint:** Use the fact that a supremum of the family of pluri-sub-harmonic functions is pluri-sub-harmonic (see [Sh], Property 3°, page 254).

**Exercise 11.5.** Prove that for small  $|y|$  we have  $\phi(iy) \approx R^{-2}|y|^2 + 2n \log \|y\|_K$ .

**Exercise 11.6.** Prove that

$$\phi(z) \leq 2n \log \frac{4}{\pi} + R^{-2}|y|^2.$$

**Exercise 11.7.** Prove that  $e^{-\phi}$  is comparable to  $|z|^{-2n}$  near the origin, so  $e^{-\phi}$  is not locally integrable at 0.

**Invariance trick.** We have  $e^{-\phi(z)} \approx |z|^{-2n}$ . Hence, the integral

$$\int_{\sigma\delta K_{\mathbb{C}} \setminus \delta K_{\mathbb{C}}} e^{-\phi(z)} dv_{2n}(z) \approx \int_{\delta}^{\sigma\delta} \frac{dr}{r}, \quad \sigma \in (1, 2), \quad \delta \in (0, \frac{1}{4}).$$

is independent of  $\delta$ . This gives us an additional flexibility. At the very end of the proof we will make a choice of a very small  $\delta$ , and  $\sigma$  very close to 1 to make the term  $e^{-2n(\log \sigma + 2C\delta)}$ , appearing in the lower estimate of  $\mathcal{K}(0, 0)$ , to be of the order  $e^{-o(n)}$ , (see (49) and Exercise 12.1).

**Exercise 11.8.** Let

$$K_{\mathbb{C}} = \{z \in \mathbb{C}^n : |z \cdot t| \leq 1 \text{ for all } t \in K^\circ\} \subset K \times K,$$

where the last inclusion is between subsets of  $\mathbb{R}^{2n}$ . Prove that

$$\phi(z) \geq 2n(\log \delta - 2C\delta) = 2n \log \delta - 4Cn\delta$$

in  $(\sigma\delta K_{\mathbb{C}}) \setminus (\delta K_{\mathbb{C}})$ .

## 11.2. The construction of the Mexican-hat function $g$ supported on $K_{\mathbb{C}}$ .

11.2.1. *Application of John's Theorem.* We assume that our origin-symmetric  $K$  is smooth enough. Since all the quantities we will use change in a very simple way under linear transformations of  $\mathbb{R}^n$ , by F. John's Theorem (see Theorem 2.1), one can replace  $K$  by its suitable linear image to ensure that  $v_n(K) = 1$ , and that  $K$  contains the ball of radius  $r_K$  and is contained in the ball of radius  $R_K$  centered at the origin with the ratio of radii  $R_K/r_K \leq \sqrt{n}$ .

**Exercise 11.9.** Prove that  $K_{\mathbb{C}}$  is convex and contains  $\frac{1}{\sqrt{2}}(K \times K)$ , which, in turn, contains the  $2n$ -dimensional ball of radius  $r_K/\sqrt{2}$  centered at the origin.

Conclude that one can construct a smooth function  $g : \mathbb{C}^n \rightarrow [0, 1]$  such that  $g = 1$  in  $\delta K_{\mathbb{C}}$ ,  $g = 0$  outside  $\sigma \delta K_{\mathbb{C}}$ , and

$$|\bar{\partial}g| = \frac{1}{2}|\nabla g| \leq \sqrt{2}r_K^{-1}[\delta(\sigma - 1)]^{-1}.$$

**Exercise 11.10.** Prove that

$$\begin{aligned} \int_{T_K} |\bar{\partial}g|^2 e^{-\phi} dv_{2n} &\leq C(\sigma, \delta) r_K^{-2} \sigma^{2n} \delta^{2n} v_{2n}(K_{\mathbb{C}}) e^{-2n \log \delta + 4Cn\delta} \\ &= C(\sigma, \delta) r_K^{-2} e^{2n(\log \sigma + 2C\delta)} v_{2n}(K_{\mathbb{C}}). \end{aligned}$$

**Exercise 11.11.** Apply the Hörmander theorem together with Exercise 11.4 to show that there exists a solution  $f$  of the equation  $\bar{\partial}f = -\bar{\partial}g$  in  $T_K$  such that

$$\begin{aligned} \int_{T_K} |f|^2 e^{-\phi} dv_{2n} &\leq C(\sigma, \delta) 4 \left( \frac{R_K}{r_K} \right)^2 e^{2n(\log \sigma + 2C\delta)} v_{2n}(K_{\mathbb{C}}) \\ &\leq C(\sigma, \delta) 4ne^{2n(\log \sigma + 2C\delta)} v_{2n}(K_{\mathbb{C}}). \end{aligned}$$

**Exercise 11.12.** Prove that  $\bar{\partial}f = 0$  in  $\delta K_{\mathbb{C}}$ , so  $f$  is analytic and, thereby, continuous in  $\delta K_{\mathbb{C}}$ . Conclude that  $f(0) = 0$ .

**Hint:** Observe that  $e^{-\phi}$  is not locally integrable at the origin, but the integral  $\int_{T_K} |f|^2 e^{-\phi} dv_{2n}$  is finite, (cf. Exercise 11.7).

## 12. PART IV. THE CONSTRUCTION OF THE ANALYTIC FUNCTION $F$ THAT HELPS TO OBTAIN THE SHARP LOWER BOUND ON $v_{2n}(K_{\mathbb{C}})\mathcal{K}(0, 0)$

12.0.2. *Almost exact lower bound on  $v_{2n}(K_{\mathbb{C}})\mathcal{K}(0, 0)$ .*

We define the function  $F$  as  $F = g + f$ , where  $\bar{\partial}f = -\bar{\partial}g$ . By the Hörmander Theorem  $F$  is analytic in  $T_K$  and satisfies  $F(0) = g(0) = 1$  (see Exercise 11.12). On the other hand,

$$\|F\|_{A^2(T_K)}^2 \leq 2[4neC(\sigma, \delta) + 1]e^{2n(\log \sigma + 2C\delta)} \left( \frac{4}{\pi} \right)^{2n} v_{2n}(K_{\mathbb{C}}).$$

Indeed,

$$\int_{T_K} |F|^2 dv_{2n} \leq 2 \int_{T_K} |g|^2 dv_{2n} + 2 \int_{T_K} |f|^2 dv_{2n},$$

where the first integral in the right-hand side does not exceed  $(\sigma\delta)^{2n}v_{2n}(K_{\mathbb{C}}) \leq v_{2n}(K_{\mathbb{C}})$ . Moreover, we can use the results of Exercises 11.6 and 11.11 to obtain an upper bound for the second one:

$$\int_{T_K} |f|^2 dv_{2n} \leq e^{2n \log \frac{4}{\pi} + 1} \int_{T_K} |f|^2 e^{-\phi} dv_{2n} \leq 4neC(\sigma, \delta) e^{2n(\log \sigma + 2C\delta)} \left( \frac{4}{\pi} \right)^{2n} v_{2n}(K_{\mathbb{C}}).$$

Now, by Exercise 10.4,

$$(49) \quad \mathcal{K}(0, 0) \geq c(\sigma, \delta) n^{-1} e^{-2n(\log \sigma + 2C\delta)} \left( \frac{\pi}{4} \right)^{2n} v_{2n}(K_{\mathbb{C}})^{-1}.$$

**Exercise 12.1.** Choose  $\delta > 0$  very small and  $\sigma$  very close to 1 to make

$$e^{-2n(\log \sigma + 2C\delta)} = e^{-o(n)}$$

as  $n \rightarrow \infty$ .

Using the previous Exercise we can rewrite (49) in the form

$$v_{2n}(K_{\mathbb{C}})\mathcal{K}(0,0) \geq e^{-o(n)} \left(\frac{\pi}{4}\right)^{2n},$$

which is almost exact as  $n \rightarrow \infty$ , (see Exercise 10.4). Recalling that

$$\mathcal{K}(0,0) = \frac{1}{(2\pi)^n} \int_{\mathbb{R}^n} \frac{dv_n(t)}{J_K(t)},$$

we get the inequality

$$v_{2n}(K_{\mathbb{C}}) \int_{\mathbb{R}^n} \frac{dv_n(t)}{J_K(t)} \geq e^{-o(n)} \left(\frac{\pi^3}{8}\right)^n$$

as  $n \rightarrow \infty$ .

It remains to get rid of the  $e^{-o(n)}$  factor.

12.0.3. *The exact lower bound on  $v_{2n}(K_{\mathbb{C}})\mathcal{K}(0,0)$ . The tensor power trick.*

Here we will again use the direct product features of  $\mathcal{P}(K)$  (see Lemma 3.2 or (41)). Fix  $n \geq 1$  and the body  $K \in \mathbb{R}^n$ . Choose a very big number  $m$  and consider  $K' = \underbrace{K \oplus \cdots \oplus K}_m \subset \mathbb{R}^{mn}$ . By Exercise 11.3, we have  $K'_{\mathbb{C}} = K_{\mathbb{C}} \oplus \cdots \oplus K_{\mathbb{C}}$  and

$J_{K'}(t_1, \dots, t_m) = J_K(t_1) \cdots J_K(t_m)$ . Applying the above inequality to  $K'$  instead of  $K$  and raising both parts to the power  $\frac{1}{m}$ , we get

$$v_{2n}(K_{\mathbb{C}}) \int_{\mathbb{R}^n} \frac{dv_n(t)}{J_K(t)} \geq e^{-o(mn)/m} \left(\frac{\pi^3}{8}\right)^n$$

as  $m \rightarrow \infty$ . Since  $o(mn)/m \rightarrow 0$  as  $m \rightarrow \infty$  and everything else does not depend on  $m$  at all, we get the clean estimate

$$v_{2n}(K_{\mathbb{C}}) \int_{\mathbb{R}^n} \frac{dv_n(t)}{J_K(t)} \geq \left(\frac{\pi^3}{8}\right)^n$$

valid for all origin-symmetric convex bodies  $K$  of volume 1 in  $\mathbb{R}^n$ . This is our desired estimate (45).

**Exercise 12.2.** Where does the constant  $\pi^3/8$  come from?

## APPENDIX A. THE PALEY-WIENER THEOREM

The general reference for this part is Theorem 7.3.1 from [Ho3]. We start with the following

**Exercise A.1.** Let  $L$  be a convex body in  $\mathbb{R}^n$ , and let

$$f(z) = \int_L e^{-iz \cdot t} dv_n(t).$$

Prove that

$$|f(iy)| \leq |L|e^{h_L(y)}.$$

**Theorem A.1. (The Paley-Wiener Theorem)** *The following two classes of functions are the same:*

*The class  $\mathbb{A}$  of all entire functions  $f : \mathbb{C}^n \rightarrow \mathbb{C}$  of finite exponential type (i.e., satisfying the bound  $|f(z)| \leq Ce^{C|z|}$  for all  $z \in \mathbb{C}^n$  with some  $C > 0$ ) such that*

- (i) their restriction to  $\mathbb{R}^n$  belongs to  $L^2$ ;*
- (ii)  $|f(iy)| \leq Ce^{\|y\|_K}$  with some  $C > 0$  for all  $y \in \mathbb{R}^n$ .*

*The class  $\mathbb{B}$  of the Fourier transforms  $f(z) = \int_{K^\circ} g(t)e^{-iz \cdot t} dv_n(t)$  of  $L^2$ -functions  $g$  supported on  $K^\circ$ .*

*Proof.* We first prove that  $\mathbb{B} \subseteq \mathbb{A}$ . By Plancherel's identity, the restriction of  $f$  to  $\mathbb{R}^n$  belongs to  $L^2$ . Moreover, from Definition 2.2 we see that  $h_{K^\circ}(y) = \|y\|_K$ , together with the Cauchy-Schwarz inequality, we obtain

$$\begin{aligned} |f(iy)| &= \left| \int_{K^\circ} g(t)e^{y \cdot t} dv_n(t) \right| \leq \int_{K^\circ} |g(t)| \sup_{t \in K^\circ} e^{y \cdot t} dv_n(t) \leq \\ &e^{h_{K^\circ}(y)} \int_{K^\circ} |g(t)| dv_n(t) \leq e^{h_{K^\circ}(y)} \|g\|_{L^2(K^\circ)} \sqrt{|K^\circ|}. \end{aligned}$$

Now we show that  $\mathbb{A} \subseteq \mathbb{B}$ . Assume for a moment that  $f \in \mathbb{A}$  satisfies

$$(50) \quad |f(z)| \leq c_N \frac{e^{h_{K^\circ}(y)}}{(1 + |z|)^N}, \quad \forall z = x + iy \in \mathbb{C}^n, \quad N \geq n + 2.$$

Since the restriction of  $f$  to  $\mathbb{R}^n$  belongs to  $L^2$ , we can write

$$g(x) = (2\pi)^{-n} \int_{\mathbb{R}^n} e^{ix \cdot \xi} f(\xi) d\xi.$$

We claim that  $g(x) = 0$  for  $x \notin K^\circ$ .

By shifting the contour of integration we obtain

$$g(x) = (2\pi)^{-n} \int_{\mathbb{R}^n} e^{ix \cdot (\xi + i\eta)} f(\xi + i\eta) d\xi = (2\pi)^{-n} e^{-x \cdot \eta} \int_{\mathbb{R}^n} e^{ix \cdot \xi} f(\xi + i\eta) d\xi.$$

Hence, changing  $\eta$  by  $t\eta$ ,  $t > 0$ , and using (50) we have

$$|g(x)| \leq \frac{C_N}{(2\pi)^n} e^{-t(x \cdot \eta - h_{K^\circ}(\eta))} \int_{\mathbb{R}^n} \frac{d\xi}{(1 + |\xi|)^N}.$$

Sending  $t$  to infinity we see that we can have  $g(x) \neq 0$  only provided  $h_{K^\circ}(\eta) \geq x \cdot \eta$  for all  $\eta \in \mathbb{R}^n$ . This gives  $x \in K^\circ$ .

The removal of the assumption (50) requires some work with distributions. We refer the reader to Theorem 7.3.1 of [Ho3] for the proof of this technical moment.  $\square$

We shall denote the class given by any of these conditions by  $PW(K)$ , and

$$(51) \quad \|f\|_{PW(K)} = \sup_{y \in \mathbb{R}^n} e^{-\|y\|_K} \sqrt{\int_{\mathbb{R}^n} |f(x + iy)|^2 dx}.$$

**Exercise A.2.** *Prove that the space of  $f$  such that  $\|f\|_{PW(K)} \leq \infty$  is the Hilbert space.*

## APPENDIX B. THE BERGMAN SPACES

The general reference for this part is [Sh], pages 371-375, see also [Kr].

**Definition B.1.** Let  $\Omega$  be a domain in  $\mathbb{C}^n$  and  $H(\Omega)$  be the space of holomorphic functions on  $\Omega$ . Consider the Hilbert Space of holomorphic functions,

$$A^2(\Omega) = \{f \in H(\Omega) : \|f\|_{\Omega}^2 = \int_{\Omega} |f|^2 dv_{2n} < \infty\}$$

with the scalar product

$$(f, g) = \int_{\Omega} f \bar{g} dv_{2n}.$$

This is our Bergman space.

**Exercise B.1.** Prove that  $A^2(\Omega)$  is non-trivial when  $\Omega$  is bounded.

**Exercise B.2.** Prove that  $A^2(\Omega)$  is trivial for  $\Omega = \mathbb{C}^n$ .

We will consider only domains for which the Bergman space is non-trivial.

**B.1. Reproducing kernel.** Fix  $\zeta \in \Omega$ . Consider the following problem: minimize  $\|f\|_{A^2(\Omega)}$  in the class

$$E = \{f \in A^2(\Omega) : f(\zeta) = 1\}.$$

**Theorem B.1.** The extremal function  $f_o(\cdot, \zeta)$  of the above problem exists and is unique.

**Definition B.2.** The kernel function of  $\Omega$  is defined as

$$\mathcal{K}_{\Omega}(z, \zeta) = \frac{f_o(z, \zeta)}{\|f_o\|_{A^2(\Omega)}^2}.$$

We will assume that  $\|f_o\|_{A^2(\Omega)} = 1$ . The proof of the following theorem can be found [Sh], page 374.

**Theorem B.2.** The kernel function  $\mathcal{K}_{\Omega}(z, \zeta)$  satisfies the following properties:

- a) It is holomorphic with respect to  $z$ , and anti-holomorphic with respect to  $\zeta$ ;
- b) It is antisymmetric:  $\mathcal{K}_{\Omega}(z, \zeta) = \overline{\mathcal{K}_{\Omega}(\zeta, z)}$ ;
- c) It is reproducing: for every  $f \in A^2(\Omega)$  at every point  $z \in \Omega$ ,

$$f(z) = \int_{\Omega} f(\zeta) \mathcal{K}_{\Omega}(z, \zeta) dv_{2n}(\zeta).$$

## APPENDIX C. THE HÖRMANDER THEOREM AND SOME OF ITS APPLICATIONS

We start with some auxiliary background related to subharmonic and pluri-subharmonic functions as well as to the notions of convexity and pseudo-convexity. We refer the reader to the books [Ho4], ([LG], Appendices A, C); [Sh], [Kr], where these notions are discussed in full detail. Below we present only facts and definitions necessary to understand Nazarov's proof of the Bourgain-Milman Theorem.

**C.1. Convexity and Pseudo-Convexity.** We start with the following exercise showing that the *convexity* of a domain could be defined using *harmonic functions*. Let

$$\mathbb{D} = \{z \in \mathbb{C} : |z| < 1\}, \quad \mathbb{T} = \{z \in \mathbb{C} : |z| = 1\}.$$

**Exercise C.1.** Let  $\Omega$  be a connected domain in  $\mathbb{R}^N$ . Then the following conditions are equivalent:

(i) For every linear map  $l : [-1, 1] \rightarrow \mathbb{R}^N$ ,  $l(\pm 1) \in \Omega$ , implies  $l([-1, 1]) \subset \Omega$ .

(ii) For every harmonic map  $h : \mathbb{D} \rightarrow \mathbb{R}^N$ ,  $h(\mathbb{T}) \subset \Omega$  implies  $h(\mathbb{D}) \subset \Omega$ .

Here the coordinates  $h_1, \dots, h_N$  of  $h$  are harmonic functions.

**Solution:** We show (i) implies (ii). Assume  $\Omega$  is convex and let a harmonic  $h$  be such that  $h(\mathbb{T}) \subset \Omega$ . Then, the mean-value formula

$$h(0) = \int_{\mathbb{T}} h(e^{i\theta}) d\theta$$

shows that  $h(0) \in \Omega$ . Let  $a \in \mathbb{D}$ ,  $a \neq 0$ , consider the *Mobius map* mapping point  $a$  to 0:

$$M : \mathbb{D} \rightarrow \mathbb{D}, \quad M(z) = \frac{z - a}{1 - \bar{a}z}.$$

To show  $h(a) \in \Omega$  we apply the mean-value formula to  $\tilde{h} = h(M^{-1})$ ,

$$M^{-1}(\xi) = \frac{\xi + a}{1 + \bar{a}\xi}.$$

Since  $M(\mathbb{T}) = \mathbb{T}$ , we have

$$h(a) = \tilde{h}(0) = \int_{\mathbb{T}} \tilde{h}(e^{i\theta}) d\theta = \int_{\mathbb{T}} h(M^{-1}(e^{i\theta})) d\theta \in \Omega.$$

Now we prove that (ii) implies (i). It is enough to show that for any linear  $l$  such that  $l(\pm 1) \in \Omega$  we have  $(l(-1) + l(1))/2 \in \Omega$ .

**Idea:** We consider an auxiliary harmonic vector  $u$  (i.e. all coordinates of  $u$  are harmonic functions) that is a convolution of the Poisson kernel  $P_r$ ,  $0 \leq r < 1$ , with a " $l(-1), l(1)$ "-function  $f_l$ ,  $u = P_r * f_l$ ,

$$f_l(e^{i\theta}) = l(1) \text{ for } \theta \in (0, \pi), \quad f_l(e^{i\theta}) = l(-1) \text{ for } \theta \in (\pi, 2\pi).$$

Then, our  $u$  "maps"  $\mathbb{T}$  into  $l(-1), l(1)$ , and

$$u(0) = \frac{1}{2\pi} \int_{\mathbb{T}} u(e^{i\theta}) d\theta = \frac{l(-1) + l(1)}{2} \in \Omega.$$

Observe that  $u|_{\mathbb{T}}$  is not harmonic, so we need "to smoothen it up".

Let  $\epsilon > 0$  be arbitrarily small to be chosen later, and let  $\gamma_1, \gamma_2$  be two disjoint paths contained in  $\Omega$  and connecting  $l(-1)$  and  $l(1)$ . Consider  $u_{r,\epsilon} = P_r * P_{1-\epsilon} * f_{l,\epsilon}$ , where  $f_{l,\epsilon} : \mathbb{T} \rightarrow \Omega$  is a *continuous* vector-function satisfying the following:

$$f_{l,\epsilon}(e^{i\theta}) = l(-1) \text{ for } \theta \in [\epsilon, \pi - \epsilon], \quad f_{l,\epsilon}(e^{i\theta}) = l(1) \text{ for } \theta \in [\pi + \epsilon, 2\pi - \epsilon],$$

and on arcs  $A_1 := \{e^{i\theta} : |\theta| \leq \epsilon\}$ ,  $A_2 := \{e^{i\theta} : \pi - \epsilon \leq |\theta| \leq \pi\}$ , we have  $f_{l,\epsilon}(A_j) = \gamma_j$ ,  $j = 1, 2$ . Now observe that for  $\epsilon$  small enough and for  $r \in [0, 1]$  we have  $u_{r,\epsilon}(\mathbb{T}) \subset \Omega$ . Hence,  $u_{r,\epsilon}(\mathbb{D}) \subset \Omega$ , and, in particular,

$$\Omega \ni u_{r,\epsilon}(0) = \frac{l(-1) + l(1)}{2} + \text{error}(\epsilon) + \int_{A_1} u_{r,\epsilon}(\theta) d\theta + \int_{A_2} u_{r,\epsilon}(\theta) d\theta.$$

Since the lengths of arcs  $A_j$  and the error term tend to zero as  $\epsilon \rightarrow 0$ , and since  $\Omega$  is open, we see that  $(l(-1) + l(1))/2 \in \Omega$ .

By the reasons which are similar to those in Exercise C.1, one can define the notion of *strict convexity*. Let  $\partial\Omega$  stand for the boundary of  $\Omega$ .

**Exercise C.2.** Let  $\Omega$  be a convex connected domain in  $\mathbb{R}^N$ . Then the following conditions are equivalent:

- (i) For every linear map  $l : [-1, 1] \rightarrow \mathbb{R}^N$ ,  $l(\pm 1) \in \partial\Omega$ , implies  $l((-1, 1)) \subset \Omega$ .
- (ii) For every harmonic map  $h : \mathbb{D} \rightarrow \mathbb{R}^N$ ,  $h(\mathbb{T}) \subset \partial\Omega$  implies  $h(\mathbb{D}) \subset \Omega$ .

**Definition C.1.** A domain  $\Omega \subset \mathbb{C}^n$  is called *pseudo-convex* if for every analytic map  $\alpha : \mathbb{D} \rightarrow \mathbb{C}^n$ ,  $\alpha(\mathbb{T}) \subset \Omega$  implies  $\alpha(\mathbb{D}) \subset \Omega$ .

Since being *analytic* is a stronger condition than being *harmonic*, we see that *pseudo-convexity* is less restrictive than *convexity*. In particular, any convex domain  $\Omega \subset \mathbb{C}^n$  is *pseudo-convex*.

**Exercise C.3.** Show that the converse is not true.

**Hint:** For  $n = 1$  it follows from the Riemann Mapping Theorem that any reasonable domain in  $\mathbb{C}$  is *pseudo-convex*, see also Exercise C.7 below. For  $n > 1$  Reinhardt domains are examples of pseudo-convex domains that are not (in general) convex, see [Sh], [Kr].

**Definition C.2.** A pseudo-convex domain  $\Omega \subset \mathbb{C}^n$  is called *strictly pseudo-convex* if for every analytic map  $\alpha : \mathbb{D} \rightarrow \mathbb{C}^n$ ,  $\alpha(\mathbb{T}) \subset \partial\Omega$  implies  $\alpha(\mathbb{D}) \subset \Omega$ .

Below we are going to use an equivalent definition of the *strict pseudo-convexity*, which is easier to check analytically. To introduce it, we remind briefly the definitions of *sub-harmonic* and *pluri-sub-harmonic* functions, [LG].

**Definition C.3.** Let  $\Omega$  be a domain in  $\mathbb{R}^N$ . A real-valued function  $\phi(x)$  with values in  $[-\infty, \infty)$  is called *sub-harmonic* in  $\Omega$ , if

- (i)  $\phi(x)$  is upper-semicontinuous and is not equal to  $-\infty$  identically;
- (ii) for any point  $x \in \Omega$  and for any  $r < d_\Omega(x) := \inf\{\|x - x'\| : x' \in \Omega^c\}$  the following inequality is valid

$$\phi(x) \leq \frac{1}{|\mathbb{S}^{N-1}|} \int_{\mathbb{S}^{N-1}} \phi(x + r\theta) d\sigma_N(\theta),$$

where  $d\sigma_N$  is a Lebesgue measure on  $\mathbb{S}^{N-1}$ .

We will denote the family of all sub-harmonic functions by  $S(\Omega)$ .

**Definition C.4.** Let  $\Omega$  be a domain in  $\mathbb{C}^n$ . A real-valued function  $\phi(z)$  with values in  $[-\infty, \infty)$  is called pluri-sub-harmonic in  $\Omega$ , if

(i)  $\phi(z)$  is upper-semicontinuous and is not equal to  $-\infty$  identically;

(ii) for any  $r$  such that  $\{z + uw : |u| \leq r, u \in \mathbb{C}\} \subset \Omega$  the following inequality is valid

$$\phi(z) \leq \frac{1}{2\pi} \int_0^{2\pi} \phi(z + re^{i\theta} w) d\theta.$$

We will denote the family of pluri-sub-harmonic in  $\Omega$  functions by  $PSH(\Omega)$ .

**Exercise C.4.** Let  $\Omega \subset \mathbb{C}^n$ . Prove that  $\log|h|$  is pluri-sub-harmonic, provided  $h$  is analytic in  $\Omega$ .

**Exercise C.5.** If  $\Omega \subseteq \mathbb{C}^n$ , then  $PSH(\Omega) \subset S(\Omega)$ , and if  $n = 1$ , then  $PSH(\Omega) = S(\Omega)$ .

**Hint:** see [Sh], Property 5° on page 254.

**Exercise C.6.** A function  $\phi \in PSH(\Omega)$  iff  $\phi$  is upper-semicontinuous,  $\phi$  is not equal to  $-\infty$  identically, and the restriction of  $\phi$  onto any complex line  $l$  intersecting  $\Omega$  is subharmonic, (or  $\phi \equiv -\infty$ ), on every open connected component of  $l \cap \Omega$ .

**Exercise C.7.** Let  $\Omega$  be any domain in  $\mathbb{C}$ . Prove that the function

$$\phi(z) = -\log \inf_{z^* \in \partial\Omega} |z - z^*|$$

is sub-harmonic in  $\Omega$ . Conclude that  $\phi_1 = \psi(\phi)$  is subharmonic in  $\Omega$  for any convex  $\psi$ , and that given any  $a \in C^\infty(\Omega)$  the integral

$$\int_{\Omega} |a(z)|^2 e^{-\phi_1(z)} dv_2(z)$$

can be made convergent by a proper choice of  $\psi$ .

**Exercise C.8.** Let  $\Omega$  be a domain in  $\mathbb{C}^n$ , and let  $\phi$  be defined as in the previous exercise. Is  $\phi$  pluri-sub-harmonic in  $\Omega$ ?

**Hint:** The function  $-\log|z - z^*|$  is harmonic in  $\Omega \subset \mathbb{C}$ . Is it harmonic in  $\Omega \cap l$ ,  $\Omega \subset \mathbb{C}^n$ ?

**Exercise C.9.** Let  $\phi$  be continuous convex (with respect to real coordinates) function in  $\Omega$ . Prove that  $\phi \in PSH(\Omega)$ .

**Hint:** Consider the following inequality

$$\phi(x) \leq \frac{1}{2}(\phi(x + y) + \phi(x - y)),$$

change  $y$  on  $ye^{i\theta}$  and integrate with respect to  $d\theta/2\pi$ .

**Remark C.1.** The last exercise shows that convex functions form a (proper) subclass of pluri-sub-harmonic ones. One can think about these classes of functions in the following (rather informative) way: convex functions are described by the non-negative Gaussian curvature, (the determinant of the (complex) Hessian matrix); (pluri)-sub-harmonic functions are described by the non-negative mean curvature, (the trace of the Hessian matrix).

**Exercise C.10.** Prove that  $\phi \in C^2(\Omega)$  is pluri-sub-harmonic iff

$$\Delta_u \phi(z + uw) \Big|_{u=0} = 4 \sum_{j,k=1}^n \frac{\partial^2 \phi}{\partial z_j \partial \bar{z}_k} w_j \bar{w}_k \geq 0$$

for any  $w \in \mathbb{C}^n$ .

**Hint:** See ([LG], Proposition I.5).

Now we are ready for our second definition of *strict pseudo-convexity*, cf. (52).

**Definition C.5.** A domain  $\Omega \subset \mathbb{C}^n$  is called **strictly pseudo-convex** if there exists a positive function  $\gamma \in PSH(\Omega) \cap C^\infty(\Omega)$  such that the matrix

$$\frac{\partial^2 \gamma}{\partial z_j \partial \bar{z}_k}(z)$$

is **positive-definite** at every point  $z \in \Omega$ , and for every  $r \in \mathbb{R}$  the set  $\Omega_r = \{z \in \Omega : \gamma(z) < r\} \subseteq \Omega$ .

The proof of the following Theorem can be found in ([Sh], pages 238-267). See also ([Kr], Theorem 3.3.5, page 144).

**Theorem C.1.** Definitions C.2 and C.5 are equivalent.

## C.2. Formulation of the Hörmander theorem.

**Theorem C.2. (Hörmander)** Let  $\Omega$  be any open domain in  $\mathbb{C}^n$ , and let  $\phi : \Omega \rightarrow \mathbb{R}$  be any pluri-subharmonic function in  $\Omega$  satisfying the inequality

$$(52) \quad \sum_{k,j=1}^n \frac{\partial^2 \phi}{\partial z_j \partial \bar{z}_k} w_j \bar{w}_k \geq \tau |w|^2$$

for all  $w \in \mathbb{C}^n$  at every point of  $\Omega$  with some  $\tau > 0$ . Then, for every  $L^2_{(0,1)}(\Omega, e^{-\phi})$  closed form

$$Q(z) = \sum_{j=1}^n a_j(z) d\bar{z}_j, \quad (\bar{\partial}Q = 0),$$

$$(Q \text{ is satisfying } \quad \frac{\partial}{\partial \bar{z}_j} a_k(z) = \frac{\partial}{\partial \bar{z}_k} a_j(z) \quad \forall z \in \Omega, \quad a_j \in L^2(\Omega, e^{-\phi})),$$

we can solve the equation

$$(53) \quad \bar{\partial}f = Q,$$

(or the system):

$$(54) \quad \frac{\partial}{\partial \bar{z}_j} f(z) = a_j(z), \quad j = 1, \dots, n,$$

and

$$(55) \quad \int_{\Omega} |f|^2 e^{-\phi} dv_{2n} \leq \tau^{-1} \int_{\Omega} \sum_{j=1}^n |a_j(z)|^2 e^{-\phi} dv_{2n}.$$

**Remark C.2.** *The existence of a pluri-sub-harmonic  $\phi$  satisfying (52) is a condition on the domain  $\Omega$ . This is a different way of saying that  $\Omega$  is strictly pseudo-convex. One can find a certain analogy in the formulation of Hörmander's Theorem with Lemma 2, page 250, of L. Ahlfors, [AL], where Perron's method for the solution of the Dirichlet problem is discussed.*

**Remark C.3.** *We assume that  $a_j$ ,  $j = 1, \dots, n$ , are very smooth and compactly supported. In the general case, (which is not needed here), it is enough to suppose that the right-hand side in (55) is finite, ([LG], Lemma III.11).*

**Remark C.4.** *Since  $\log |h|$  is pluri-sub-harmonic in  $\Omega$ , provided  $h$  holomorphic there, (see Exercise C.4), it is natural to write the weights in estimate (55) in the form  $e^{-\phi}$ , with  $\phi$  pluri-subharmonic.*

**Remark C.5.** *Our data consists of the functions  $a_j$  appearing in the right-hand side of (54) together with the pluri-sub-harmonic  $\phi$  satisfying (52). In this notes the main application of Hörmander's Theorem will be to construct analytic functions in the tube domain  $T_K$  using the properly chosen data.*

### C.3. From sub-harmonic to analytic. Examples in the case $n = 1$ .

We put  $\bar{\partial} = \partial/\partial\bar{z}$ ,  $\partial = \partial/\partial z$ .

C.3.1. *The example of a non-trivial analytic function  $F = F(\phi, g)$  obtained after the application of the Hörmander Theorem, and depending on the sub-harmonic (convex)  $\phi(z) = |z|^2$ , and an infinitely smooth compactly supported Mexican-hat function  $g$  that is 1 in  $rB_2^2$ ,  $r > 0$ , and 0 outside  $(r+1)B_2^2$ ,  $\Omega = \mathbb{C}$ .*

If  $n = 1$ , then (52) is red as

$$(56) \quad \frac{\partial^2 \phi(z)}{\partial z \partial \bar{z}} \geq \tau, \quad \tau > 0.$$

For  $\phi(z) = |z|^2 = z\bar{z}$  we have  $\tau = \partial\bar{\partial}\phi(z) = 1 > 0$ , and we can apply Hörmander's Theorem.

Our system (54) and estimate (55) are red as

$$(57) \quad \frac{\partial}{\partial \bar{z}} f(z) = a(z),$$

and

$$(58) \quad \int_{\mathbb{C}} |f(z)|^2 e^{-|z|^2} dv_2(z) \leq \int_{\mathbb{C}} |a(z)|^2 e^{-|z|^2} dv_2(z).$$

**Idea:** we take an auxiliary function  $g$  and will be looking for  $F$  in the form  $F = f + g$ , where  $f$  is going to be a solution of (57) with  $a = -\bar{\partial}g$ . Then

$$\bar{\partial}F = \bar{\partial}f + \bar{\partial}g = a + \bar{\partial}g = -\bar{\partial}g + \bar{\partial}g = 0,$$

hence  $F$  is analytic. The point is to choose  $g$  in such a way that  $F$  would be non-trivial. In other words, we should choose  $g$  such that the equation  $\bar{\partial}f = -\bar{\partial}g$  would have a solution *different from the trivial one*  $f = -g$ . To achieve this we will use (58).

**Remark C.6.** *Unfortunately, we will not see  $F$ , this construction is very implicit.*

We remind that **our data** consists of the pluri-sub-harmonic function  $|z|^2$ , and an infinitely smooth compactly supported Mexican-hat function  $g$  that is 1 in  $rB_2^2$ ,  $r > 0$ , and 0 outside  $(r+1)B_2^2$ . We can assume that  $|\bar{\partial}g| \leq 1$ , (the width of the ring  $(r+1)B_2^2 \setminus rB_2^2$ ).

The introduction of  $r$  will give us a certain *freedom*. We will choose the proper  $r > 0$  at the end.

**Trick:** Since  $g$  is constant outside of the ring  $(r+1)B_2^2 \setminus rB_2^2$ , (it is 1 inside and 0 outside), the derivative function  $\bar{\partial}g$  is non-trivial only inside  $(r+1)B_2^2 \setminus rB_2^2$ .

**Exercise C.11.** *Prove that*

$$\|a\|_{L^2(e^{-\phi})}^2 = \|\bar{\partial}g\|_{L^2(e^{-\phi})}^2 \leq e^{-r^2} \pi(2r+1).$$

**F is non-trivial.** We claim that for  $r$  large enough  $F(0) > 0$ . Indeed,  $F(0) = f(0) + g(0)$ ,  $g(0) = 1$ , and it is enough to show that  $|f(0)| < 1$  for  $r$  large enough. By the Hörmander Theorem, (58) yields

$$\|f\|_{L^2(e^{-\phi})}^2 \leq \|a\|_{L^2(e^{-\phi})}^2 \leq e^{-r^2} \pi(2r+1),$$

and this is the place, where we can use the freedom in  $r$ . Observe that  $|f(0)|$  is very small,

$$\begin{aligned} |f(0)|^2 &\leq \frac{1}{\pi} \int_{\mathbb{D}} |f(z)|^2 dv_2(z) \leq \frac{e}{\pi} \int_{\mathbb{D}} |f(z)|^2 e^{-|z|^2} dv_2(z) \leq \\ &\frac{e}{\pi} \int_{\mathbb{C}} |f(z)|^2 e^{-|z|^2} dv_2(z) \leq \frac{e}{\pi} e^{-r^2} \pi(2r+1) = (2r+1)ee^{-r^2}, \end{aligned}$$

provided  $r$  is large enough.

Here the first inequality follows from the analyticity of  $f$  in  $\mathbb{D}$  ( $\bar{\partial}f = -\bar{\partial}g = 0$  in  $\mathbb{D}$ ), and the second one is a consequence of the fact that  $\phi(z) \leq 1$  in  $\mathbb{D}$ .

**Remark C.7.** *Due to Liouville's Theorem, we may not give any upper bound on the integral  $\int_{\mathbb{C}} |F(z)|^2 dv_2(z)$ , but we can bound  $\int_{\mathbb{C}} |F(z)|^2 e^{-|z|^2} dv_2(z)$ . Observe that we did not see whether  $F \equiv \text{Const}$  or not.*

**Exercise C.12.** *Let  $g$  be an infinitely smooth compactly supported function equal to  $1+z$  in  $rB_2^2$ ,  $r > 0$ , and 0 outside  $(r+1)B_2^2$ . What kind of  $F$  will we get?*

C.3.2. *The above example reworked. We take the same  $g$ , but change the previous sub-harmonic function onto  $\phi(z) = |z|^2 + \log|z|^2$ ,  $\Omega = \mathbb{C}$ .*

**Exercise C.13.** *Prove that (56) holds for new  $\phi$  and we can apply Hörmander's Theorem. What is  $\tau$ ?*

We put  $F = g + f$ , where  $f$  is going to be a solution of (57) with  $a = -\bar{\partial}g$ , as above.

**Trick.** Observe that

$$\int_{B_2^2} |f(z)|^2 e^{-|z|^2 - \log|z|^2} dv_2(z) < \infty, \quad \int_{B_2^2} |g(z)|^2 e^{-|z|^2 - \log|z|^2} dv_2(z) = \infty.$$

Indeed,  $e^{-\phi(z)} = e^{-|z|^2 - \log |z|^2}$  is *not* locally integrable near the origin, hence the second integral is divergent. On the other hand we have

$$\tau \int_{B_2^2} |f(z)|^2 e^{-|z|^2 - \log |z|^2} dv_2(z) \leq \int_{\mathbb{C}} |\bar{\partial}g(z)|^2 e^{-|z|^2 - \log |z|^2} dv_2(z) < \infty.$$

**Exercise C.14.** *Prove the last statement.*

**Exercise C.15.** *Let  $F, f, g$  be as above. Prove that  $f(0) = 0$ , hence,  $F(0) = 1$ , and  $F$  is non-trivial.*

**Hint:** Use the previous exercise.

**Additional trick.** Our choice of  $\phi(z) = |z|^2 + \log |z|^2$  has an additional advantage over the choice  $\phi(z) = |z|^2$ . Namely, observe that the integral

$$\int_{\mathbb{C}} e^{-\phi} dv_2 \approx \int_r^{(r+1)} \frac{d\rho}{\rho} = \int_{\delta r}^{\delta(r+1)} \frac{d\rho}{\rho}$$

is independent on  $\delta$ . Hence, we could try to get a better upper bound on the integral  $\int_{\mathbb{C}} |F(z)|^2 e^{-|z|^2} dv_2(z)$  using the freedom with  $\delta$ .

**Exercise C.16.** *Take any two different points  $z_1, z_2$  in  $\mathbb{C}$ , and consider*

$$\phi(z) = |z|^2 + \log |z - z_1|^2 + \log |z - z_2|^2.$$

*Choose  $\tilde{g}(z) = \alpha_1 g_{z_1}(z) + \alpha_2 g_{z_2}(z)$  where  $g_{z_1} = g(z - z_1)$ ,  $g_{z_2} = g(z - z_2)$ ,  $\alpha_1 \neq \alpha_2$ , and the supports of  $g_{z_1}, g_{z_2}$  are disjoint. Prove that  $F = F(\tilde{g}, \phi)$  satisfies  $F(z_1) = \alpha_1$ ,  $F(z_2) = \alpha_2$ .*

**C.4. The example of a non-trivial analytic function  $F = F(\phi, g)$  obtained after the application of the Hörmander Theorem in the strip  $\Omega = T_K$ .**

We assume that  $K = [-1, 1]$ , and put  $K_{\mathbb{C}} = B_2^2 \subset K \times K$ .

The idea of the construction of a non-trivial analytic  $F$  in the strip (the tube domain)  $T_K = \{z \in \mathbb{C} : |\operatorname{Im}z| < 1\}$  is very similar to the one considered above. Since our goal here to get a good upper bound on

$$\int_{T_K} |F(z)|^2 dv_2(z) < \infty,$$

we have to make a more careful choice of our pluri-sub-harmonic  $\phi$ . The point is that the function  $\phi(z) = |z|^2 + \log |z|^2$  is *not bounded* in  $T_K$ , and we are not able to make an estimate

$$\int_{T_K} |F(z)|^2 dv_2(z) \leq \sup_{z \in T_K} e^{\phi(z)} \int_{T_K} |F(z)|^2 e^{-\phi(z)} dv_2(z).$$

We will also adjust our Mexican-hat function  $g$ . Namely, we define a smooth function  $g : \mathbb{C} \rightarrow [0, 1]$  such that  $g = 1$  in  $\delta K_{\mathbb{C}}$ ,  $g = 0$  outside  $\sigma \delta K_{\mathbb{C}}$ , ( $\sigma = r + 1 > 1$  in our previous notation), and

$$|\bar{\partial}g| = \frac{1}{2} |\nabla g| \leq \sqrt{2} [\delta(\sigma - 1)]^{-1}.$$

**Getting around the unboundedness of  $\phi$  in  $T_K$ .** Since the class of pluri-subharmonic functions is invariant under composition with *conformal* mappings, (see [Sh], Section 37, page 244), one can try to map  $T_K$  conformally on the disc of radius  $4/\pi$  centered at the origin. Following Nazarov we put

$$\phi(z) = |y|^2 + 2 \log |\Phi(z)|, \quad \Phi(z) = \frac{4 e^{\frac{\pi}{2}z} - 1}{\pi e^{\frac{\pi}{2}z} + 1}.$$

The normalization is chosen in such a way that  $\Phi'(0) = 1$ .

**Exercise C.17.** Prove that  $\forall z \in T_K$  we have

$$(59) \quad \phi(z) \leq 2 \log \frac{4}{\pi} + |y|^2,$$

and  $\phi$  is bounded on  $T_K$ . Observe that the first term  $|y|^2$  is added just to make sure that (56) is satisfied.

**Exercise C.18.** Prove that

$$\phi(z) \geq 2(\log \delta - 2C\delta) = 2 \log \delta - 4C\delta$$

in  $(\sigma\delta K_{\mathbb{C}}) \setminus (\delta K_{\mathbb{C}})$ .

**Hint:** Note that  $\Phi(0) = 0$  and  $\Phi'(0) = 1$ . Show that

$$|\log |\Phi(z)| - \log |z|| \leq C |z|, \quad \text{for } |z| \leq \frac{1}{2} \quad \text{with some } C \geq 1.$$

**Exercise C.19.** Prove that

$$\|F\|_{A^2(T_K)}^2 \leq C v_2(K_{\mathbb{C}}).$$

What is  $C$ ?

**Hint:** Observe at first that

$$\int_{T_K} |F|^2 dv_2 \leq 2 \int_{T_K} |g|^2 dv_2 + 2 \int_{T_K} |f|^2 dv_2,$$

and that the first integral in the right-hand side does not exceed  $v_2(K_{\mathbb{C}})$ . Next, use Exercise C.18 to prove

$$\int_{T_K} |f|^2 e^{-\phi} dv_2 \leq \frac{1}{\tau} \frac{(\sigma\delta)^2 - \delta^2}{2(\sigma - 1)^2 \delta^2} v_2(K_{\mathbb{C}}) e^{-2 \log \delta - C\delta} \leq \frac{\sigma + 1}{2\tau(\sigma - 1)} e^{-2 \log \delta - C\delta} v_2(K_{\mathbb{C}}),$$

and use (59) and (58) to show that

$$\int_{T_K} |f|^2 dv_2 \leq e^{2 \log \frac{4}{\pi} + 1} \frac{\sigma + 1}{2\tau(\sigma - 1)} e^{-2 \log \delta - C\delta} v_2(K_{\mathbb{C}}).$$

Finally, obtain

$$\int_{T_K} |F|^2 dv_2 \leq 2e^{2 \log \frac{4}{\pi} + 1} v_2(K_{\mathbb{C}}) \left( (\sigma\delta)^2 + \frac{\sigma + 1}{2\tau(\sigma - 1)} e^{-2 \log \delta - C\delta} \right).$$

Can we change  $\phi$  to use a proper  $\tau$ ?

APPENDIX D. PROOF OF HÖRMANDER'S THEOREM

**Main Idea of the proof:** In order to show the existence of a solution of PDE, it is enough to obtain a certain *weighted*  $L^2$  (Hilbert space) estimate.

**Main Ingredients of the proof:** The proof (roughly) consists of an Elementary Linear Algebra and Integration by parts.

**Basic Linear Algebra Fact:** Let  $A : H \rightarrow H$  be a linear operator acting on a *finite-dimensional Hilbert space*  $H$ . Then

$$(60) \quad \dim(\ker(A)) + \dim(\text{Im}(A)) = \dim(H).$$

**One more Linear Algebra Idea:** Let  $A : H \rightarrow G$ , where  $G$  is a subspace of  $H$ . To show that  $A$  is *onto*, i.e.,  $\text{Im}(A) = G$ , it is enough to check that

$$(61) \quad \ker(A^*) = \{0\}.$$

**Exercise D.1.** *Prove the last statement.*

**Hint:** It is enough to show that  $\dim(\text{Im}(A)) = \dim(G)$ . Since  $\text{rank}(A^*) = \text{rank}(A)$ , ( $\text{rank}(A) = \dim(\text{Im}(A))$ ), and  $\ker(A^*) = \{0\}$  we have

$$\begin{aligned} \dim(\text{Im}(A)) &= \dim(\text{Im}(A^*)) = \dim(\text{Im}(A^*)) + 0 = \\ &= \dim(\text{Im}(A^*)) + \dim(\ker(A^*)) = \dim(G), \end{aligned}$$

where in the last equality we used (60) with  $A = A^* : G \rightarrow H$ .

**Idea:** Condition (61) can be reformulated: assume that there exists a constant  $C > 0$  such that

$$(62) \quad \forall y \in G, \quad \|A^*y\|_H \geq C\|y\|_H (= \|y\|_G).$$

**Exercise D.2.** *Prove the last statement.*

**Hint:** If  $0 \neq y \in \ker A^*$ , then  $\|A^*y\|_H = 0$  implies  $\|y\|_H = 0$ , a contradiction.

The next Lemma is an *infinitely-dimensional* analogue of what was said above. At first we don't want to deal with subtleties related to closed densely defined operators, so we formulate everything "just for the Hilbert space".

**Lemma D.1.** *Let  $G$  be a closed subspace of  $H$ , and let  $A : H \rightarrow G \subseteq H$  be a linear operator. Assume that there exists a constant  $C > 0$  such that (62) holds. Then,*

$$\forall y \in G \exists x \in H : Ax = y, \quad \|x\|_H \leq C\|y\|_H.$$

**Idea:** The solution  $x$  we are looking for will come from the Riesz Theorem (about linear functionals in Hilbert Spaces) if we construct a certain linear functional  $L$  on  $H_1$ ,  $L(a) = (x, a)$ . In other words, given  $f \in G$ , we want  $x : Ax = f$ , that is equivalent to  $(Ax, y) = (f, y) \forall y \in G$ .

*Proof.* We are looking for  $x$  satisfying  $x \cdot A^*y = f \cdot y$ , and it is natural to define  $L$  on  $H$  (more precisely on  $\text{Im}(A^*)$ ) as  $L(A^*y) = f \cdot y$ . Then

$$|L(A^*y)| = |f \cdot y| \leq \|f\|\|y\| \leq \|f\|\|A^*y\|,$$

and we can extend  $L$  to  $H$ . Now, there exists unique  $x \in H$ ,

$$f \cdot y = L(A^*y) = x \cdot A^*y = Ax \cdot y,$$

and we are done.

Finally, we have

$$\|x\| = \sup_{\|A^*y\|=1} x \cdot A^*y = \sup_{\|A^*y\|=1} Ax \cdot y \leq \|Ax\| \|y\| \leq C \|Ax\| \|A^*y\| \leq C \|Ax\|.$$

□

Finally, the reader is advised to prove (or to read the proof of) the following statement, which is Lemma III.4 in [LG], page 318.

**Lemma D.2.** *Let  $A$  be a closed operator with a dense domain  $D_A$  in a Hilbert space  $H$ , and let  $A : D_A \rightarrow G$ , where  $G$  is a closed subspace of  $H$ . Then  $G = A(D_A)$  iff there exists a constant  $C > 0$  such that (62) is true for all  $y \in G \cap D_{A^*}$ .*

D.0.1. *Integration by parts.*

We use integration by parts to compute  $A^*$ . We assume at first that functions  $f, g$  are continuously differentiable, and  $\phi$  is twice continuously-differentiable. We have

$$\begin{aligned} (\bar{\partial}f, g)_{L^2(e^{-\phi})} &= \int_{\mathbb{C}} \bar{\partial}f(z) \bar{g}(z) e^{-\phi(z)} dv(z) = - \int_{\mathbb{C}} f(z) \bar{\partial}(\bar{g}(z) e^{-\phi(z)}) dv(z) = \\ &= - \int_{\mathbb{C}} f(z) \overline{Dg}(z) e^{-\phi(z)} dv(z) = -(f, Dg), \quad Dg = \partial g - g\partial\phi. \end{aligned}$$

Thus,

$$(63) \quad A^* = \bar{\partial}^* = -D, \quad Dg = \partial g - g\partial\phi.$$

Observe that if  $\phi(z) = \infty$  for  $z \in \Omega^c$ , then the characteristic function  $\chi_\Omega$  can be written as  $\chi_\Omega = e^{-\phi}$ , and we can run the integration by parts argument with  $\Omega \subseteq \mathbb{C}$  instead of  $\mathbb{C}$ .

We will see in a moment what conditions we would like to impose on  $\phi$  and  $\Omega$ .

D.0.2. *We solve  $\bar{\partial}f = a$  in  $L^2(\Omega, e^{-\phi})$ ,  $n = 1$ .*

Let all functions in question be smooth enough.

By Linear Algebra, to show the existence of the solution of (57) it is enough to prove that

$$(64) \quad \forall g \in \text{Dom}(D), \quad \|Dg\|_{L^2(\Omega, e^{-\phi})} \geq C \|g\|_{L^2(\Omega, e^{-\phi})},$$

where  $D$  is conjugate to  $\bar{\partial}$ , see (63).

Observe that

$$\bar{\partial}Dg = \bar{\partial}(\partial g - g\partial\phi) = \bar{\partial}\partial g - \bar{\partial}g\partial\phi - g\bar{\partial}\partial\phi, \quad D\bar{\partial}g = \partial\bar{\partial}g - \partial\phi\bar{\partial}g,$$

and  $\partial\bar{\partial} = \bar{\partial}\partial$  yields

$$(65) \quad \bar{\partial}Dg = D\bar{\partial}g - (D\bar{\partial}g - \bar{\partial}D) = D\bar{\partial}g - g\bar{\partial}\partial\phi.$$

Finally, integration by parts,  $D^* = -\bar{\partial}$  and (65) imply (64):

$$\begin{aligned} \|D^*g\|_{L^2(e^{-\phi})}^2 &= (Dg, Dg) = -(g, \bar{\partial}Dg) = -(g, D\bar{\partial}g) - (g, (\bar{\partial}D - D\bar{\partial})g) = \\ &= (\bar{\partial}g, \bar{\partial}g) + (g, g\bar{\partial}\partial\phi) \geq \tau^2 \|g\|_{L^2(e^{-\phi})}^2, \end{aligned}$$

provided  $\phi : \partial\bar{\partial}\phi(z) \geq \tau$  for every  $z \in \Omega$ . This is our condition on  $\Omega$  and  $\phi$ .

**Exercise D.3.** Prove (58) in the case  $n = 1$ ,  $\Omega = \mathbb{C}$ .

D.0.3. The multidimensional case,  $\Omega = \mathbb{C}^n$ .

Assume again that all functions in question are smooth enough. Now we have a closed  $(0, 1)$  form

$$w = \sum_{j=1}^n a_j d\bar{z}_j, \quad \bar{\partial}w = 0.$$

Repeating the one-dimensional argument, for  $\partial_j = \partial/\partial\bar{z}_j$  we have

$$\bar{\partial}^* \left( \sum_{j=1}^n g_j d\bar{z}_j \right) = - \sum_{j=1}^n D_j g_j d\bar{z}_j \quad D_j g_j = \partial_j g_j - g_j \partial_j \phi_j.$$

Indeed, for two  $(0, 1)$  forms,

$$\bar{\partial}f = \sum_{j=1}^n \frac{\partial f}{\partial \bar{z}_j} d\bar{z}_j, \quad g = \sum_{j=1}^n g_j d\bar{z}_j,$$

as in the one-dimensional case,

$$(\bar{\partial}f, g) = \sum_{j=1}^n \int_{\Omega} \frac{\partial f(z)}{\partial \bar{z}_j} \bar{g}_j(z) e^{-\phi(z)} dv_{2n}(z) = - \sum_{j=1}^n \int_{\Omega} f(z) \bar{D}_j \bar{g}_j(z) e^{-\phi(z)} dv_{2n}(z).$$

Now,

$$\left( \sum_{j=1}^n D_j g_j, \sum_{k=1}^n D_k g_k \right) = \sum_{j=1}^n \sum_{k=1}^n (D_j g_j, D_k g_k) =$$

(we integrate by parts in each variable and use  $D_j^* = \bar{\partial}_j$ ),

$$- \sum_{j=1}^n \sum_{k=1}^n (g_j, \bar{\partial}_j D_k g_k) = \sum_{j=1}^n \sum_{k=1}^n (g_j, (D_k \bar{\partial}_j - \bar{\partial}_j D_k) g_k) =$$

$$\sum_{j=1}^n \sum_{k=1}^n (\bar{\partial}_k g_j, \bar{\partial}_j g_k) + \sum_{j=1}^n \sum_{k=1}^n (g_j, g_k \bar{\partial}_j \partial_k \phi) \geq \text{const} \sum_{j=1}^n \sum_{k=1}^n (g_j, g_k).$$

Observe that  $\bar{\partial}w = 0$  yields  $\bar{\partial}_k a_j = \bar{\partial}_j a_k$ , hence, for  $a_j = g_j$ ,  $(\bar{\partial}_k g_j, \bar{\partial}_j g_k) \geq 0$ .

**Exercise D.4.** Prove (58) in the case  $\Omega = \mathbb{C}^n$ .

The proof of the general case of a strictly pseudo-convex domain  $\Omega \subset \mathbb{C}^n$  can be found in [Ho4], [LG], pages 316-327. The idea is to reduce the general case to the case  $\Omega = \mathbb{C}^n$  by writing the characteristic function  $\chi_{\Omega}$  as  $\chi_{\Omega} = e^{-\varphi}$ , where a *pluri-subharmonic*  $\varphi(z) = \infty$  for  $z \notin \Omega$ . If the functions  $a_j$ ,  $j = 1, \dots, n$ , are blowing up near the boundary of  $\Omega$ , one can use the idea similar to the one described in Exercise C.7 in the one-dimensional case, to come up with the proper pluri-subharmonic  $\phi$  to tame the growth of  $a_j$ s.

## REFERENCES

- [AL] L. AHLFORS, *Complex Analysis*, Third Edition, McGraw Hill, Inc, 1979.
- [Ba] K. BALL, *Isometric problems in  $l_p$  and sections of convex sets*, PhD Dissertation, Cambridge, 1986.
- [Ba1] K. BALL, *Cube slicing in  $\mathbb{R}^n$* , Proc. Amer. Math. Soc. 97 (1986), 465–473.
- [Ba2] K. BALL, *Shadows of convex bodies*, Trans. Amer. Math. Soc. 327 (1991), 891-901.
- [Ba3] K. BALL, *Some remarks on the geometry of convex sets*, Geometric aspects of functional analysis (1986/87), Lecture Notes in Math., 1317, Springer-Verlag, Berlin-Heidelberg-New York, 1988, 224–231.
- [Ba4] K. BALL, *An Elementary Introduction to Modern Convex Geometry*, in "Flavors of Geometry", Edited by Silvio Levy, Mathematical Sciences Research Institute Publications, 31, Cambridge Univ. Press (1997).
- [Bl] E.D. BOLKER, *A class of convex bodies*, Trans. Amer. Math. Soc. 145 (1969), 323–345.
- [BF] T. BONNESEN AND FENCHEL, *Theory of convex bodies*, Springer-Verlag, 1974.
- [BL] J. BOURGAIN, J. LINDENSTRAUSS, *Projection bodies*, Israel Seminar (G.A.F.A.) 1986-87, Lecture Notes in Math., vol. 1317, Springer-Verlag, Berlin and New York, 1988, 250-269.
- [BM] J. BOURGAIN, V. MILMAN, *New volume ratio properties for convex symmetric bodies in  $\mathbb{R}^n$* , Invent. Math. 88 (1987), 319–340.
- [BP] H. BUSEMANN, C.M. PETTY, *Problems on convex bodies*, Math. Scand. 4 (1956), 88–94.
- [Fa] K. J. FALCONER, *Applications of a result on spherical integration to the theory of convex sets*, Amer. Math. Monthly, 90 (1983), 690-693.
- [FMZ] M. FRADELIZI, M. MEYER, AND A. ZVAVITCH, *An application of shadow systems to Mahler's conjecture*, Discrete & Computational Geometry, 48 (2012), no 3, 721-734.
- [Ga1] R.J. GARDNER, *Geometric Tomography*, second edition, Cambridge University Press, New York, 2006.
- [Ga2] R. J. GARDNER, *The Brunn-Minkowski inequality*, Bull. Amer. Math. Soc., 39 (2002), 355–405.
- [GRYZ] R.J. GARDNER, D. RYABOGIN, V. YASKIN, AND A ZVAVITCH, *On a problem of Klee*, J. Differential Geometry, 91 (2012), 261-279.
- [GS] I.M. GELFAND, G. E. SHILOV, *Generalized functions 1*, Academic Press, New York, 1964.
- [GV] I.M. GELFAND, N.YA. VILENKIN, *Generalized functions 4. Applications of harmonic analysis*, Academic Press, New York, 1964.
- [GPV] A. GIANNOPOULOS, G. PAOURIS, AND B. VRITSIOU, *The isotropic position and the reverse Santaló inequality*, to appear in Israel J. Math..
- [GR] A. GONCHAROV, D. RYABOGIN, *On a question of A. Koldobsky*, J. of Math. Analysis and Applications, 350, (2009), 313-326
- [GW] P. GOODEY, AND W. WEIL, *Centrally symmetric bodies and the spherical Radon transform*, J. Dif. Geom., 35, (1992), 675-688.
- [GW2] P. GOODEY, AND W. WEIL, *Zonoids and generalizations*, In Handbook of convex geometry, ed. by P. M. Gruber and J. M. Wills, North Holland, Amsterdam, 1993, 1297-326.
- [GSW] P. GOODEY, R. SCHNEIDER AND W. WEIL, *On the determination of convex bodies by projection functions*, Bull. London Math. Soc.29 (1997), 82–88.
- [GMR] Y. GORDON, M. MEYER AND S. REISNER, *Zonoids with minimal volume-product - a new proof*, Proc. Amer. Math. Soc., 104, (1988), 273-276.
- [GM] Y. GORDON AND M. MEYER, *On the Minima of the Functional Mahler Product*, Houston J. Math., to appear.
- [Gr] H. GROEMER, *Geometric applications of Fourier series and spherical harmonics*, Cambridge Univ. Press, New York, 1996.
- [Gru] B. GRUNBAUM, *Convex Polytopes*. Graduate Texts in mathematics, 221, Springer, 2003.
- [Ho1] L. HÖRMANDER,  *$L^2$  estimates and existence theorems for the  $\bar{\partial}$  operator*, Acta Math. vol. 113 (1965), pp. 89–152

- [Ho2] L. HÖRMANDER, *A history of existence theorems for the Cauchy-Riemann complex in  $L^2$  spaces*, Journal of Geometric Analysis, vol. 13 (2003), no. 2, pp. 329–357.
- [Ho3] L. HÖRMANDER, *The Analysis of Linear Partial Differential Operators I*, Springer-Verlag, 1983.
- [Ho4] L. HÖRMANDER, *An Introduction to Complex Analysis in Several Variables*, Springer-Verlag, 1966.
- [Hs] C.-I. HSIN, *The Bergman kernel on tube domains*, Rev. Unión Mat. Argentina vol. 46 (2005), no. 1, pp. 23–29.
- [Kl] V. KLEE, *Facet-centroids and volume minimization*, Studia Sci. Math. Hungar. 21 (1986), 143–147.
- [K] J. KIM, *Minimal volume product near Hanner polytopes*, submitted. Available from <http://arxiv.org/pdf/1212.2544>
- [KR] J. KIM AND S. REISNER, *Local minimality of the volume-product at the simplex*, Mathematika, 57, (2011), 121–134.
- [Kl1] V. KLEE, *Is a body spherical if its HA-measurements are constant?*, Amer. Math. Monthly, 76, (1969), 539–542.
- [Kl2] V. KLEE, *Shapes of the future*, Amer. Scientist **59** (1971), 84–91.
- [K1] A. KOLDOBSKY, *Intersection bodies, positive definite distributions and the Busemann-Petty problem*, Amer. J. Math., 120, (1998), 827–840.
- [K2] A. KOLDOBSKY, *Intersection bodies in  $\mathbb{R}^4$* , Adv. Math., 136, (1998), 1–14.
- [K5] A. KOLDOBSKY, *Fourier Analysis in Convex Geometry*, Math. Surveys and Monographs, 116, AMS, Providence RI 2005.
- [KRZ] A. KOLDOBSKY, D. RYABOGIN AND A. ZVAVITCH, *Projections of convex bodies and the Fourier transform*, Israel J. Math., 139 (2004), 361–380.
- [KY] A. KOLDOBSKY, V. YASKIN, *The interplay between convex geometry and harmonic analysis*, CBMS Regional Conference Series in Mathematics, Amer. Math. Soc., Providence RI, 2008, 108 pp.
- [Ko] A. KORÁNYI, *The Bergman kernel function for tubes over convex cones*, Pacific J. Math., vol. 12 (1962), no. 4, pp. 1355–1359.
- [Kr] S. KRANTZ, *Function Theory of Several Complex variables*, Second Edition, AMS Chelsea Publishing, AMS, Providence, Rhode Island, 1992.
- [Ku] G. KUPERBERG, *From the Mahler Conjecture to Gauss Linking Integrals*, Geometric And Functional Analysis, 18/ 3, (2008), 870–892.
- [LG] P. LELONG, P. GRUMAN, *Entire functions of Several Complex variables*, Springer-Verlag, 1989.
- [Le] P. LÉVY, *Théorie de l'addition de variable aléatoires*, Gauthier-Villars, Paris, 1937.
- [LP] J. LINDENSTRAUSS AND A. PELCZYNSKI, *Absolutely summing operators in  $L^p$  spaces and their applications*, Studia Math., 29 (1968), 257–326.
- [Lus] L. A. LUSTERNIK, *Die Brunn-Minkowskischer Ungleichung für beliebige messbare Mengen*, Dokl. Acad. Sci. SSSR, 8, (1935), 55–58.
- [Ma1] K. MAHLER, *Ein Minimalproblem für konvexe Polygone*, Mathematika (Zutphen) B7 (1939), 118–127.
- [Ma2] K. MAHLER, *Ein Übertragungsprinzip für konvexe Körper*, Časopis Pěst. Mat. Fys. 68 (1939), 93–102.
- [MMO] E. MAKAI, H. MARTINI, T. ÓDOR, *Maximal sections and centrally symmetric bodies*, Mathematika, 47, (2000), 19–30.
- [Mart] H. MARTINI, *Shadow-boundaries of convex bodies*, Journal Discrete Mathematics, Special issue on combinatorics archive, 155, Issue 1-3, (1996).
- [Me] M. MEYER, *Une caractérisation volumique de certains espaces normes de dimension finie*. Israel J. Math. 55 (1986), no. 3, 317–326.
- [MS] V. MILMAN AND G. SCHECHTMAN, *Asymptotic Theory of Finite Dimensional Normed Spaces*, Lecture Notes in Mathematics 1200, Springer Ver. (2001).
- [MePa] M. MEYER AND A. PAJOR, *On Santaló inequality*, Geometric aspects of functional analysis (1987–88), Lecture Notes in Math. 1376, Springer Ver. (1989), 261–263.
- [N] F. L. NAZAROV, *Personal discussions*, Kent State.

- [Naz] F. NAZAROV, *The Hormander proof of the Bourgain-Milman Theorem*, GAFA Seminar Notes, Lecture Notes in Mathematics, Vol. 2050, (2012), pp 335–343.
- [NRZ] F. NAZAROV, D. RYABOGIN, AND A. ZVAVITCH, *On the local equatorial characterization of zonoids and intersection bodies*, Advances in Mathematics, 217 (2008), no. 3, 1368–1380.
- [NRZ2] F. NAZAROV, D. RYABOGIN, AND A. ZVAVITCH, *Non-uniqueness of convex bodies with prescribed volumes of sections and projections*, Mathematika, 59 (2013), 213–221.
- [NRZ3] F. NAZAROV, D. RYABOGIN, AND A. ZVAVITCH, *An asymmetric convex body with maximal sections of constant volume*. to appear in J. of AMS.
- [NPRZ] F. NAZAROV, F. PETROV, D. RYABOGIN, AND A. ZVAVITCH, *A remark on the Mahler conjecture: local minimality of the unit cube*, Duke Mathematical Journal, 154 (2010), no 3, 419–430.
- [Pan] G. YU. PANINA, *The representation of an  $n$ -dimensional body in the form of a sum of  $(n - 1)$ -dimensional bodies*, English transl., Soviet J. Contemporary Math. Anal, 23 (1988), 91–103.
- [P] C. M. Petty, *Projection bodies*, Proc. Coll. Convexity (Copenhagen 1965), Kobenhavns Univ. Mat. Inst., 234–241.
- [Pi] G. PISIER, *The volume of convex bodies and Banach space geometry*, Cambridge Tracts in Mathematics, 94. Cambridge University Press, Cambridge, 1989.
- [Pog] A. V. POGORELOV, *Extrinsic Geometry of Convex Surfaces*, Volume Thirty-five of Translations of Mathematical Monographs, AMS, Providence, 1973.
- [R1] S. REISNER, *Zonoids with minimal volume-product*, Math. Zeitschrift 192 (1986), 339–346.
- [R2] S. REISNER, *Minimal volume product in Banach spaces with a 1-unconditional basis*, J. London Math. Soc. 36 (1987), 126–136.
- [RSW] S. REISNER, C. SCHÜTT, AND E. WERNER, *A note on Mahler’s conjecture*, International Math. Research Notices, no. 1, (2012), pp. 1–16.
- [R] O. S. ROTHHAUS, *Domains of Positivity*, Abh. Math. Semin. Hamburg, vol. 24 (1960), pp. 189–235.
- [Ru] W. RUDIN, *Functional analysis*, McGraw-Hill, New Yourk, 1973.
- [RY] D. RYABOGIN AND V. YASKIN, *Detecting symmetry in star bodies*, J. of Math. Analysis and Applications, 395 (2012), 509–514.
- [SR] J. SAINT-RAYMOND, *Sur le volume des corps convexes symetriques*, Sem. d’Initiation a l’Analyse, 1980–1981, no.11.
- [Sa] L.A. SANTALO, *Un invariante afin para los cuerpos convexos del espacio de  $n$  dimensiones*, Portugal J. Math. 8 (1949), 155–161.
- [Sh] B. V. SHABAT, *Introduction to Complex Analysis*, Vol II, in Russian.
- [Schl] J. SCHLAERTH, *Local and equatorial characterization of unit balls of subspaces of  $L_p$ ,  $p \geq 0$  and properties of the generalized cosine transform*, Journal of Mathematical Analysis and Applications, to appear.
- [Sc1] R. SCHNEIDER, *Zu einem problem von Shephard über die projektionen konvexer Körper*, Math. Z., 101, (1967), 71–82.
- [Sc2] R. SCHNEIDER, *Convex bodies: the Brunn-Minkowski theory*, Cambridge University Press, Cambridge, 1993.
- [Sc3] R. SCHNEIDER, *Zonoids whose polars are zonoids*, Proc., of AMS, 50, (1974), 365–368.
- [Sc4] R. SCHNEIDER, *Functional equations connected with rotations and their geometric applications*, L’Enseign. Math., 16, (1970), 297–305.
- [Sc5] R. SCHNEIDER, *On the Busemann Area in Minkowski Spaces*, Contributions to Algebra and Analysis, Vol. 42 (2001), No. 1, 263–273.
- [ScW] R. SCHNEIDER, W. WEIL, *Zonoids and related topics*, In Convexity and Its Applications, ed. by P. M. Gruber and J. M. Wills, Birkhauser, Basel, 1983,, 296–317.
- [Shep] G.C. SHEPHARD, *Shadow systems of convex bodies*, Israel J. Math., 2, (1964), 229–306.
- [St] A. STANCU, *Two volume product inequalities and their applications*, Canad. Math. Bull. 52 (2009), 464–472.
- [StW] E. STEIN AND G. WEISS, *Fourier Analysis on Euclidean Space*, Princeton University Press, Princeton, NJ, 1971.

- [Su] A. SUMMERSVILLE, *Computer simulations on Mahler's conjecture in three dimensions*, REU program, summer 2006, preprint.
- [T] T. TAO, *Santaló's inequality*, <http://terrytao.wordpress.com/2007/03/08/open-problem-the-mahler-conjecture-on-convex-bodies/>.
- [Th] A. Thompson, *Minkowski geometry*, Cambridge University Press, 1996.
- [Web] R. Webster, *Convexity*, Oxford University Press, 1994.
- [W] W. WEIL, *Blaschkes Problem der lokalen Charakterisierung von Zonoiden*, Arch. Math., 29 (1977), 655-9.
- [Z] A. ZVAVITCH, *The Busemann-Petty problem for arbitrary measures*, Math. Ann. 331, (2005), 867-887.

DEPARTMENT OF MATHEMATICS, KENT STATE UNIVERSITY, KENT, OH 44242, USA  
*E-mail address:* ryabogin@math.kent.edu

DEPARTMENT OF MATHEMATICS, KENT STATE UNIVERSITY, KENT, OH 44242, USA  
*E-mail address:* zvavitch@math.kent.edu